

Fixed to Hand chain trolley C1 max 630 kg (perpendicular version)

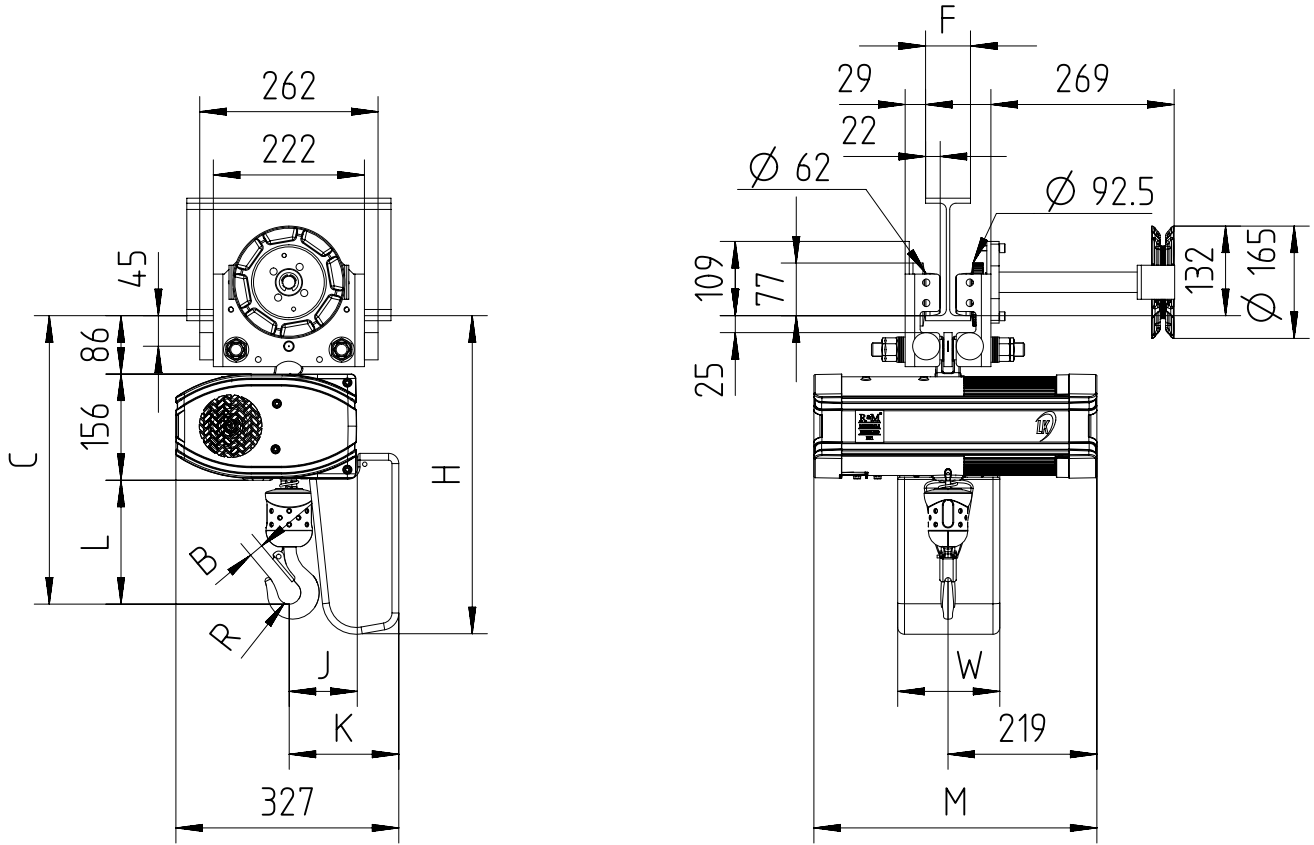

55 < F < 310

Note: Mini. radius of curve for C1 trolley is 2m.

Chain Size (mm)	Max load (kg)	Falls	Chain bag capacity (m)	Dimensions (mm)										Weight of chain (kg/m)	Estimated weight of hoist incl. trolley w/o chain (kg)			
				B	C	L	R	J	K	H	W	M			LK	LK Inverter	GLS	DB
												LK	LK Inverter/DB/GLS					
5X14	630	1	6	21	424	182	17	100	161	468	150	416	548	0.57	47	56	51	53
			16							533								
			25							653								

GLS: Gear Limit Switch  
DB : Double Brake