

DOUBLE GIRDER, HIGH, 4 PART SINGLE

Hoist type:

SX4 041...DH

SI-60Hz

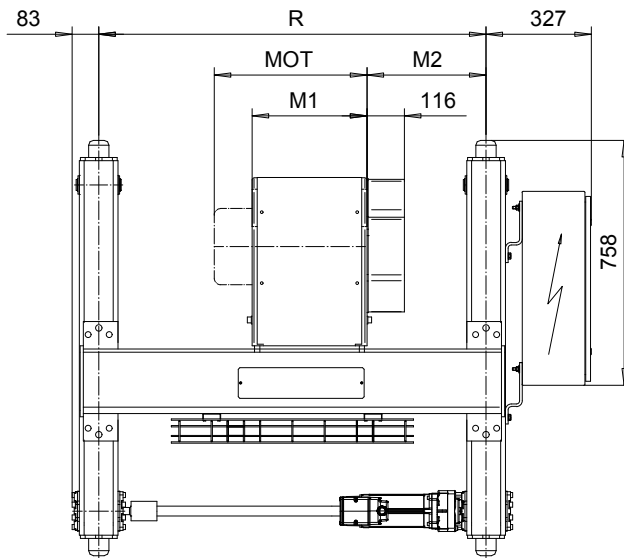
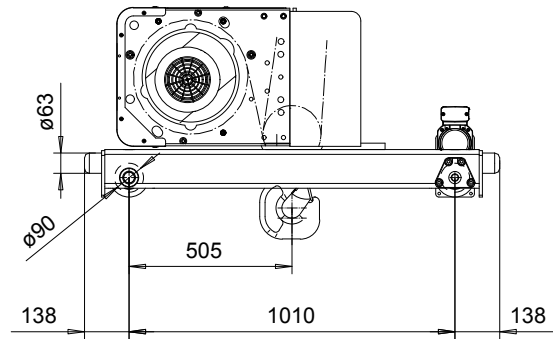
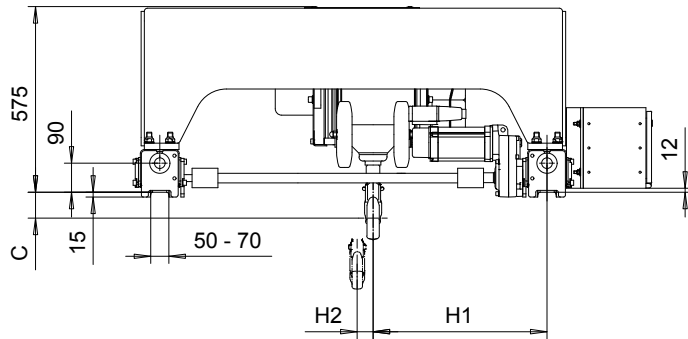

| Headroom - C dimension | |
|--------------------------------------|--------|
| Standard | 80 mm |
| with HS22 Hook operated limit switch | 170 mm |

| Motor | P3 | P4 | A3 | S3 | S5 |
|-------------|-----|-----|-----|-----|-----|
| MOT (mm) | 476 | 574 | 446 | 526 | 602 |
| Weight (kg) | 35 | 53 | 32 | 28 | 53 |

| HOL (m) | Length code | M1 (mm) | M2 (mm) | H1 (mm) | H2 (mm) | min R (mm) | Approx Weight (kg) |
|---------|-------------|---------|---------|---------|---------|------------|--------------------|
| 6 | B | 356 | 217 | 386 | 49 | 900 | 325 |
| 9 | C | 456 | 217 | 386 | 74 | 900 | 335 |
| 12 | D | 556 | 217 | 386 | 99 | 900 | 355 |
| 15 | E | 676 | 367 | 536 | 129 | 1200 | 375 |

| Load (kg) | Class |
|-----------|---------|
| 3200 | Fem/ISO |
| 4000 | 3m/M6 |
| 5000 | 2m/M5 |

Note: minR is minimum rail gauge when second brake is supplied
 Standard rail gauges are 1200, 1400, 1700, and 2000 mm
 H1, M2 calculated at minR and weight calculated with P3 motor.

This document is the absolute property of R&M Materials Handling, Inc. This document must not be copied without the written permission of R&M Materials Handling, Inc. The contents thereof must not be disclosed to a third party nor be used for any unauthorized purpose. Contravention will be prosecuted.

| | | | | |
|--------------------------------------|--|-----------|-------------|----------------|
| Design | Chd | Appd | Ref Drawing | QB-H-04 |
| Date | TROLLEY; DOUBLE GIRDER | | | 1:10 Folder |
| SLEQENG1 Owner Dept | HIGH, 4 ROPE FALLS | | | |
| R&M MATERIALS HANDLING INC. | R&M MATERIALS HANDLING, INC. HOST & CRANE PRODUCTS SPRINGFIELD, OHIO | D002230-A | | Issue 6 |