

SPACEMASTER II HAND GEARED & MOTOR DRIVEN TROLLEYS

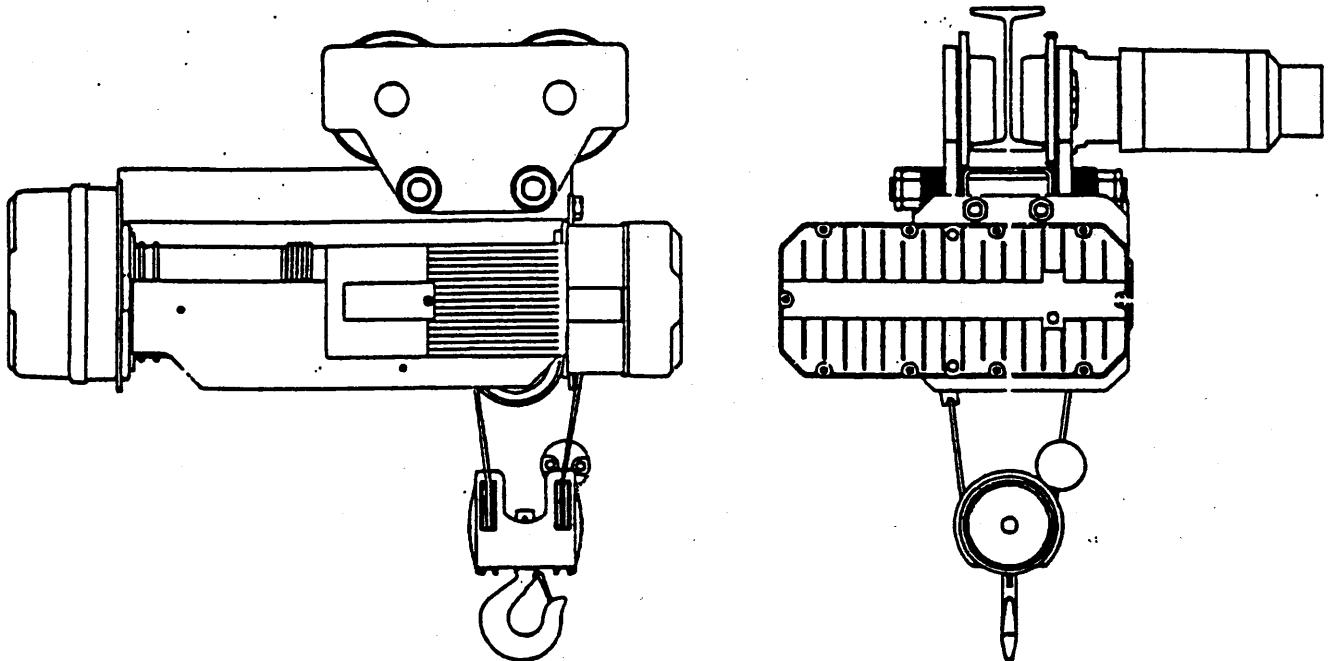

INSTALLATION, OPERATION AND MAINTENANCE INSTRUCTIONS

SERIAL NO.: _____

(Record Hoist Serial Number for Future Reference)



IMPORTANT

This manual is supplemental to the hoist installation, operation and maintenance instructions.

Before proceeding with the installation, operation or maintenance of the trolley it is important that the installation, operating and maintenance personnel read this bulletin carefully in order to ensure the safe and efficient use of the trolley and hoist.

Also, it is strongly recommended that the personnel responsible for the operation, inspection and servicing of this hoist, read and follow the Safety Standard ANSI B30.6-1987 (or current revised edition) covering Overhead Hoists (underhung) as promulgated by the American National Standards Institute and published by the American Society of Mechanical Engineers. Copies of this publication are available from the Society at United Engineering Center, 345 East 47th St., New York, NY 10017.

If any instructions are unclear or if the hoist manual is not available, contact the manufacturer or distributor of the hoist before attempting to install or use the hoist and/or trolley.

Manufactured by: **R&M Materials Handling, Inc.**
4501 Gateway Boulevard
Springfield, Ohio 45502
(937) 328-5100
Telex 205 427
FAX (937) 325-5319

Index	FR-C Number	Page No.
Hand Geared Trolley Drive Assembly	HC-1-1	1
Push Type Trolley Assembly	PC-1-2	2
Motor Driven Trolley Assembly, Short Wheelbase	MC-5-1	3
Motor Driven Trolley Assembly, Long Wheelbase	MC-5-2	4
Trolley Adjustment	PC-1-2	5
Trolley Drive Gearcase and Motor Assembly, 2 Reduction	GC-1-2	6
Trolley Drive Motor Brake Assembly, 2 Reduction Gearcase	BC-2-1	7
Trolley Drive Motor Brake Adjustment, 2 Reduction Gearcase	BC-2-2	8

**MOTOR DRIVEN TROLLEY ASSEMBLY
SHORT WHEELBASE**

**SPARE PARTS IDENTIFICATION
MC-5-1**

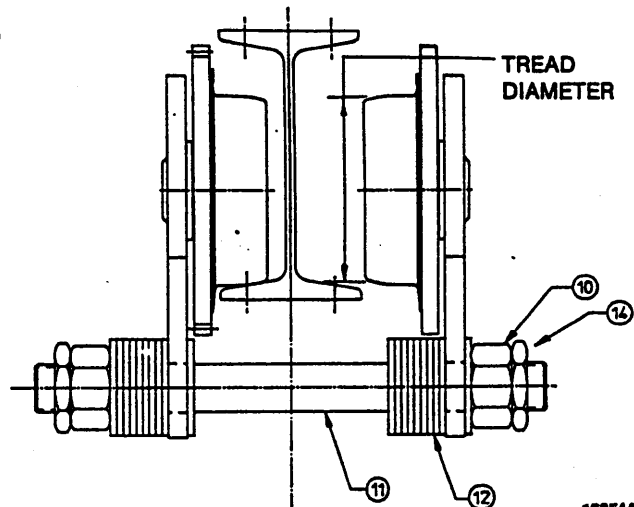
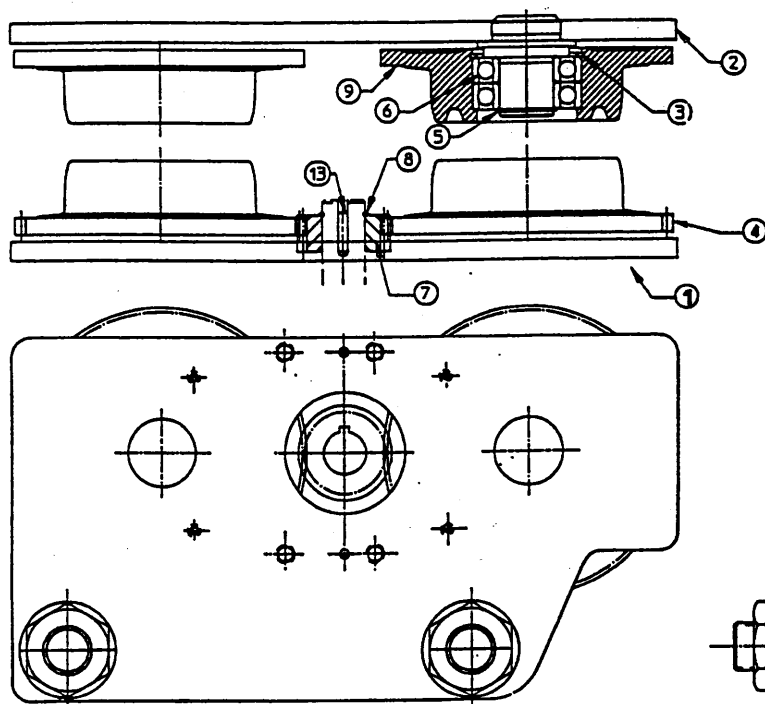

16854A

DWG. ITEM	REFERENCE NUMBER	PART DESCRIPTION	QTY.	DWG. ITEM	REFERENCE NUMBER	PART DESCRIPTION	QTY.
1	C80001	TROLLEY SIDE PLATE, GEARED	1				
2	C80002	TROLLEY SIDE PLATE, PLAIN	1				
3	C80003	RETAINING RING	4				
4	C80006	WHEEL, GEARED	2				
5	C80004	RETAINING RING	4				
6	C80007	BALL BEARING	8				
7	C80020	PINION, DRIVE	1				
8	C80021	RETAINING RING	1				
9	C80005	WHEEL, PLAIN	2				
10	C80008	HEX NUT	4				
11	C80009	STUD, TROLLEY MOUNTING	2				
12	C80010	WASHER, TROLLEY ADJUST.	A/R				
13	C80022	KEY, DRIVE PINION	1				
14	C80011	STOP NUT	4				

HOIST SERIAL NUMBER AND PART REFERENCE NUMBER MUST BE PROVIDED WHEN ORDERING REPLACEMENT PARTS.

**SPARE PARTS IDENTIFICATION
MC-5-2**

**MOTOR DRIVEN TROLLEY ASSEMBLY
LONG WHEELBASE**

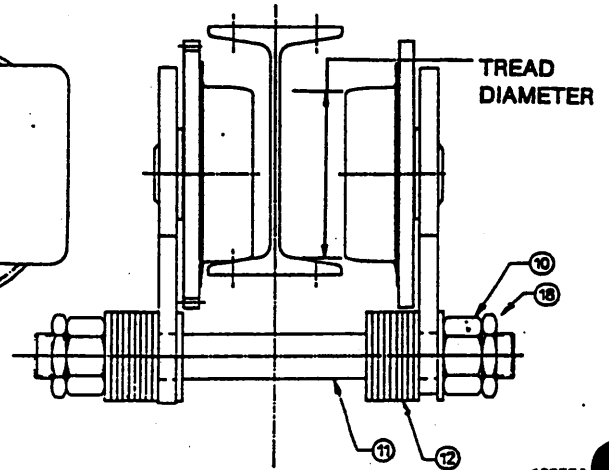
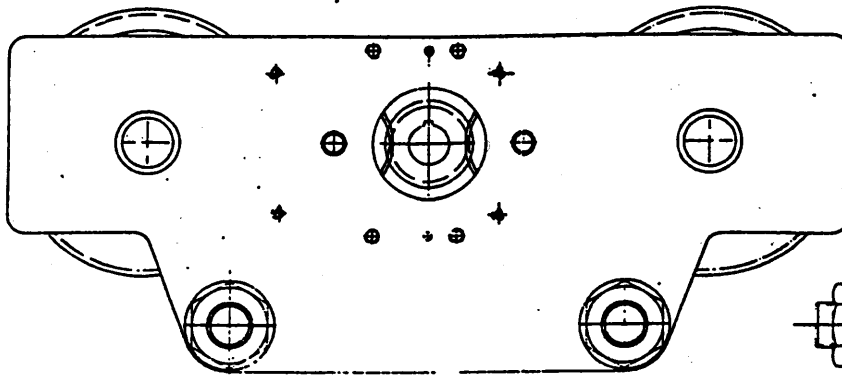
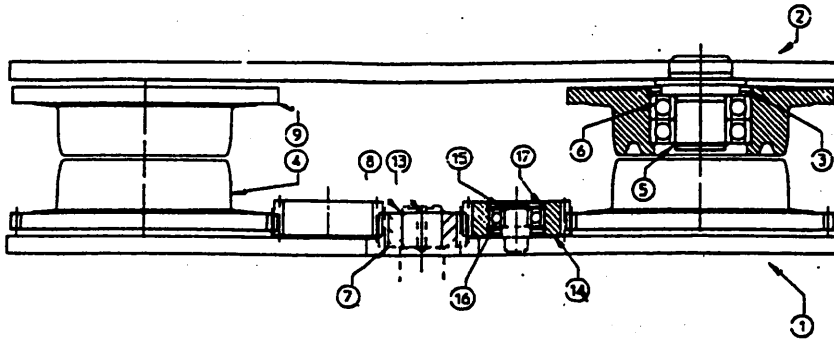

16855A

DWG. ITEM	REFERENCE NUMBER	PART DESCRIPTION	QTY.	DWG. ITEM	REFERENCE NUMBER	PART DESCRIPTION	QTY.
1	C80001	TROLLEY SIDE PLATE, GEARED	1				
2	C80002	TROLLEY SIDE PLATE, PLAIN	1				
3	C80003	RETAINING RING	4				
4	C80006	WHEEL, GEARED	2				
5	C80004	RETAINING RING	4				
6	C80007	BALL BEARING	8				
7	C80020	PINION, DRIVE	1				
8	C80021	RETAINING RING	1				
9	C80005	WHEEL, PLAIN	2				
10	C80008	HEX NUT	4				
11	C80009	STUD, TROLLEY MOUNTING	2				
12	C80010	WASHER, TROLLEY SPACING	A/R				
13	C80022	KEY, DRIVE PINION	1				
14	C80023	GEAR, IDLER	2				
15	C80024	RETAINING RING	2				
16	C80025	BALL BEARING	2				
17	C80026	RETAINING RING	4				
18	C80011	STOP NUT	4				

HOIST SERIAL NUMBER AND PART REFERENCE NUMBER MUST BE PROVIDED WHEN ORDERING REPLACEMENT PARTS.

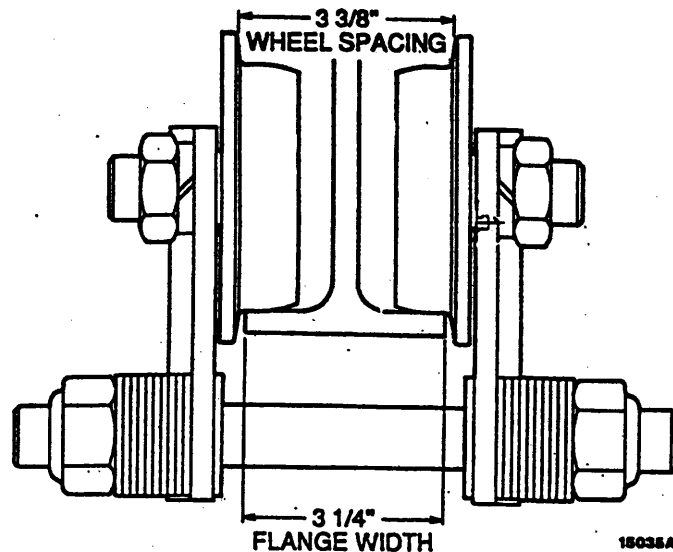
TROLLEY ADJUSTMENT
FOR 3 1/4" FLANGE
MONORAIL BEAM**Trolley Wheel Setting**

Trolleys are designed to operate on I-beams, WF sections or patented monorail beams. The drawing above illustrates the trolley adjusted for a patented monorail beam with a 3 1/4" flange width, the minimum for which the trolley is designed.

When for use on standard mill rolled "I" or "WF" sections, the clearance between the wheel flange and the rail with the hoist/trolley centered on the beam must be 1/8" each side, 1/4" total. Example: for a 5" flange width the dimension between the wheel flanges must be 5 1/4".

Note: If binding occurs while negotiating curves in the track, the trolley must be adjusted to provide 1/16" maximum additional clearance each side between wheel and "I" or "WF" beam flanges when positioned on a straight section of the track.

To adjust wheel setting, spacers are provided at the trolley mounting studs. Placing additional spacers inside, between the trolley side plate and the hoist load bar, will accommodate wider rail flanges. Removing spacers from the inside and placing them to the outside of the trolley side plates reduces the wheel spacing for smaller rail flanges.

IMPORTANT

All spacer washers must be used, either inside or outside, to assure proper tightening of the trolley mounting studs. The same number of inside spacers must be used on each side to keep the hoist centered under the monorail and to maintain proper balance. If trolley is adjusted to the maximum design flange width, one (1) washer on each stud must remain outside of the trolley side plate, each side.

WARNING

Do not replace standard mounting studs with longer studs, or add or subtract spacer washers. Studs and washers furnished with your hoist accommodate the minimum and maximum design flange widths. Special trolleys must be ordered for beam flange widths which exceed the maximum for which your trolley was designed.

**SPARE PARTS IDENTIFICATION
GC-1-2**

**TROLLEY DRIVE GEAR CASE AND MOTOR ASSEMBLY
2 REDUCTION**

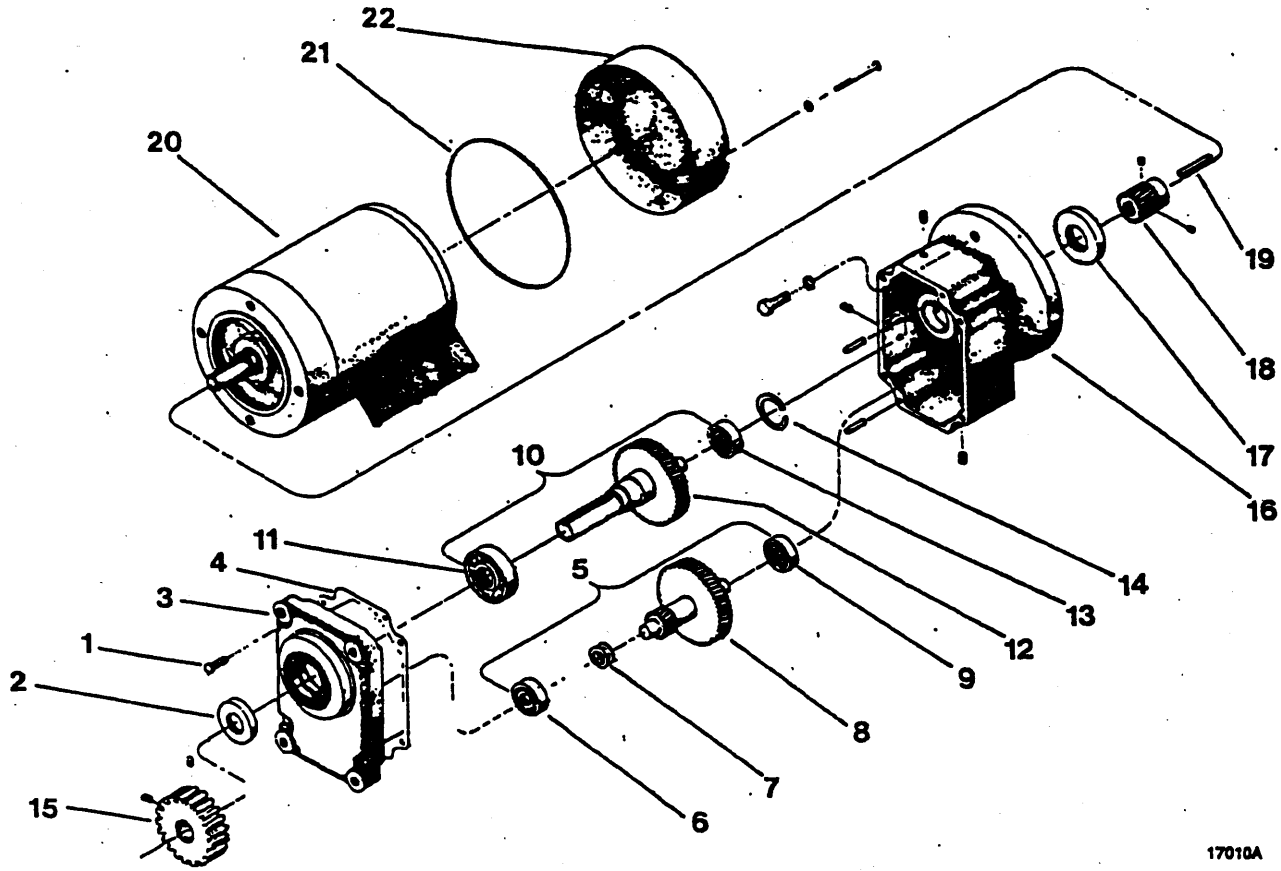

17010A

*Use this reference number for ordering complete assembly.
**For use on units equipped with brake.

DWG. ITEM	REFERENCE NUMBER	PART DESCRIPTION	QTY.	DWG. ITEM	REFERENCE NUMBER	PART DESCRIPTION	QTY.
1	C80201	SCREW, COVER	4	24	C80250	REPAIR KIT — INCLUDES ITEMS 2, 4, 5, 10, 17	1
2	C80202	OIL SEAL	1	25	C80200	COMPLETE GEARCASE ASSY.	1
3	C80203	COVER, GEARCASE	1				
4	C80204	GASKET, COVER	1				
5	C80205	INTERMEDIATE SHAFT ASSY.	1				
6	C80206	BEARING	1				
7	C80207	SPACER	A/R				
8	C80208	INTERMEDIATE SHAFT & GEAR	1				
9	C80209	BEARING	1				
10	C80210	DRIVE SHAFT ASSEMBLY	1				
11	C80211	BEARING	1				
12	C80212	DRIVE SHAFT & GEAR	1				
13	C80213	BEARING	1				
14	C80214	SNAP RING	1				
15	C80020	PINION, DRIVE	1				
16	C80216	GEAR BASE	1				
17	C80217	OIL SEAL	1				
18	C80218	PINION, MOTOR	1				
19	C80219	KEY, PINION	1				
20	C80220	MOTOR	1				
21	C80221	"O" RING SEAL	1				
22	C80222	COVER, MOTOR END **	REF				
23	C80223	GEAR MOTOR ASSY. *	REF				

HOIST SERIAL NUMBER AND PART REFERENCE NUMBER MUST BE PROVIDED WHEN ORDERING REPLACEMENT PARTS.

**TROLLEY DRIVE MOTOR BRAKE ASSEMBLY
2-REDUCTION GEARCASE**

**SPARE PARTS IDENTIFICATION
BC-2-1**

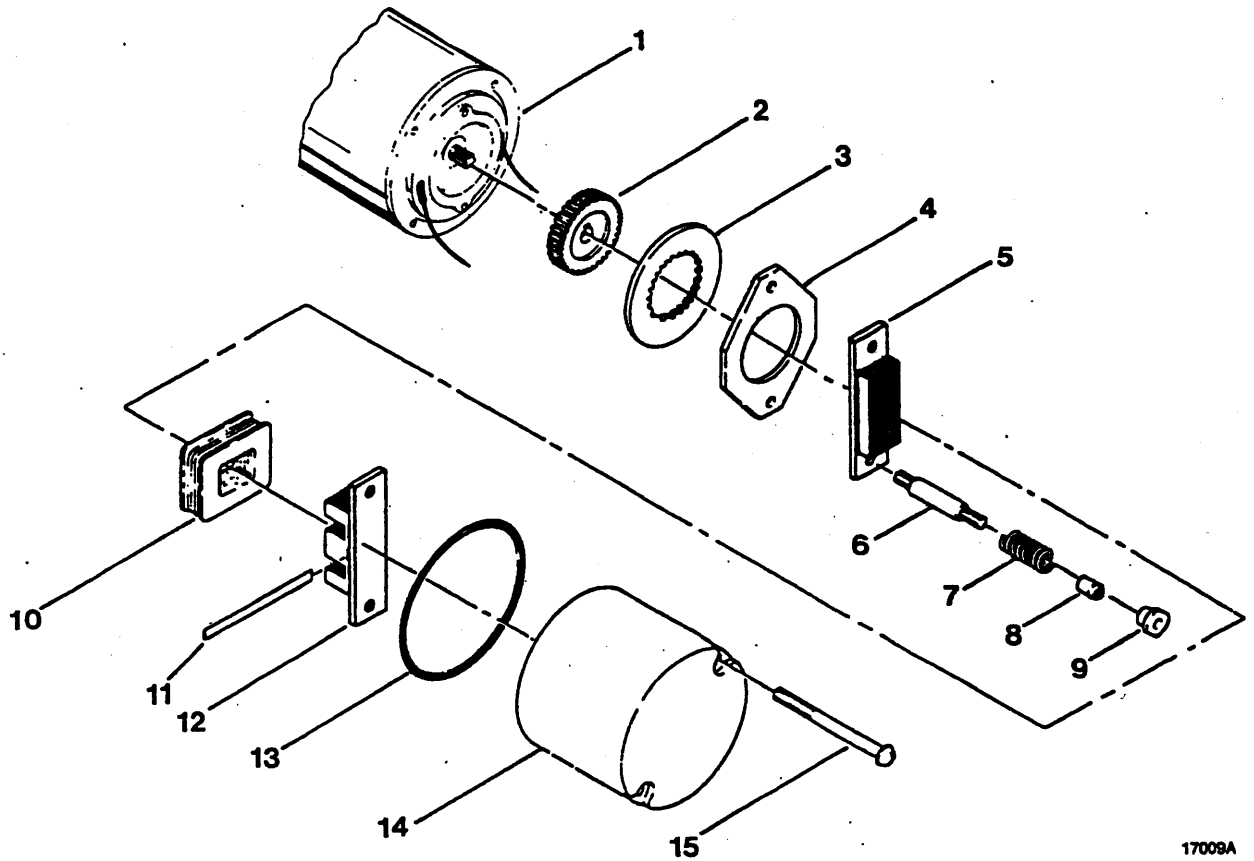

17009A

*Use this number when ordering complete assembly.

DWG. ITEM	REFERENCE NUMBER	PART DESCRIPTION	QTY.	DWG. ITEM	REFERENCE NUMBER	PART DESCRIPTION	QTY.
1	C80401	MOTOR (REFERENCE)	1				
2	C80402	BRAKE HUB	1				
3	C80403	DISC, FRICTION	1				
4	C80404	DISC, INTERMEDIATE	1				
5	C80405	ARMATURE PLATE ASSY.	1				
6	C80406	STUD	2				
7	C80407	SPRING	2				
8	C80408	SPACER	2				
9	C80409	NUT, ADJUSTING	2				
10	C80410	COIL, MAGNET	1				
11	C80411	WEDGE	1				
12	C80412	POLE PLATE ASSY.	1				
13	C80413	GASKET	1				
14	C80414	COVER, BRAKE	1				
15	C80415	BOLT COVER	2				
16	C80400	COMPLETE BRAKE ASSY.	1				
17	C80417	MAGNET REPAIR KIT (INCLUDES ITEMS 4 THRU 12)	1				

HOIST SERIAL NUMBER AND PART REFERENCE NUMBER MUST BE PROVIDED WHEN ORDERING REPLACEMENT PARTS.

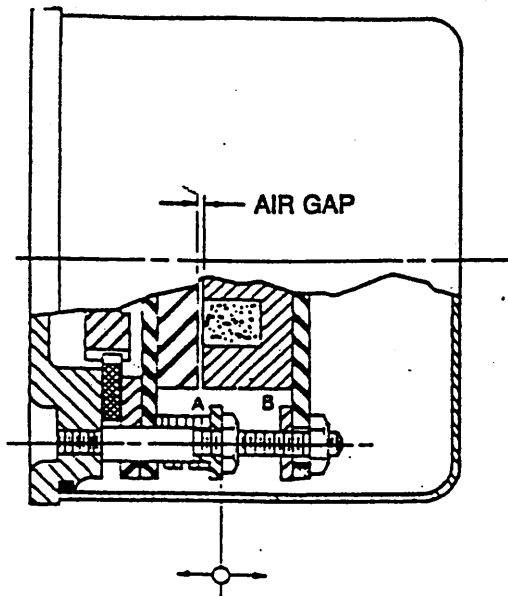

MOVE THIS DIRECTION
TO INCREASE TORQUE
AND PROVIDE QUICKER
STOP.

MOVE THIS DIRECTION
TO REDUCE TORQUE AND
PROVIDE SMOOTHER
STOP.

17013A

TORQUE ADJUSTMENT:

Brakes used on hoist motion drives are to be adjusted for maximum torque.

Brakes used on trolley and crane motion drives can be adjusted to provide stopping action to suit operations.

To adjust, loosen jam nuts at adjusting nuts "A" and adjust both sides equally as indicated by direction of arrows. Relock jam nuts after proper setting is determined.

WEAR ADJUSTMENT:

Loosen jam nuts at adjusting nuts "B" and adjust both sides to get uniform $1/32"$ (.031") air gap in magnet assembly. Relock jam nuts securely and recheck to insure proper air gap. Adjustment for wear is indicated when air gap exceeds $1/16"$. Friction disc should be replaced when worn to $1/8"$ thickness.