

Fixed to electric travel trolley TMU-C3 max 3200 Kg (perpendicular version)

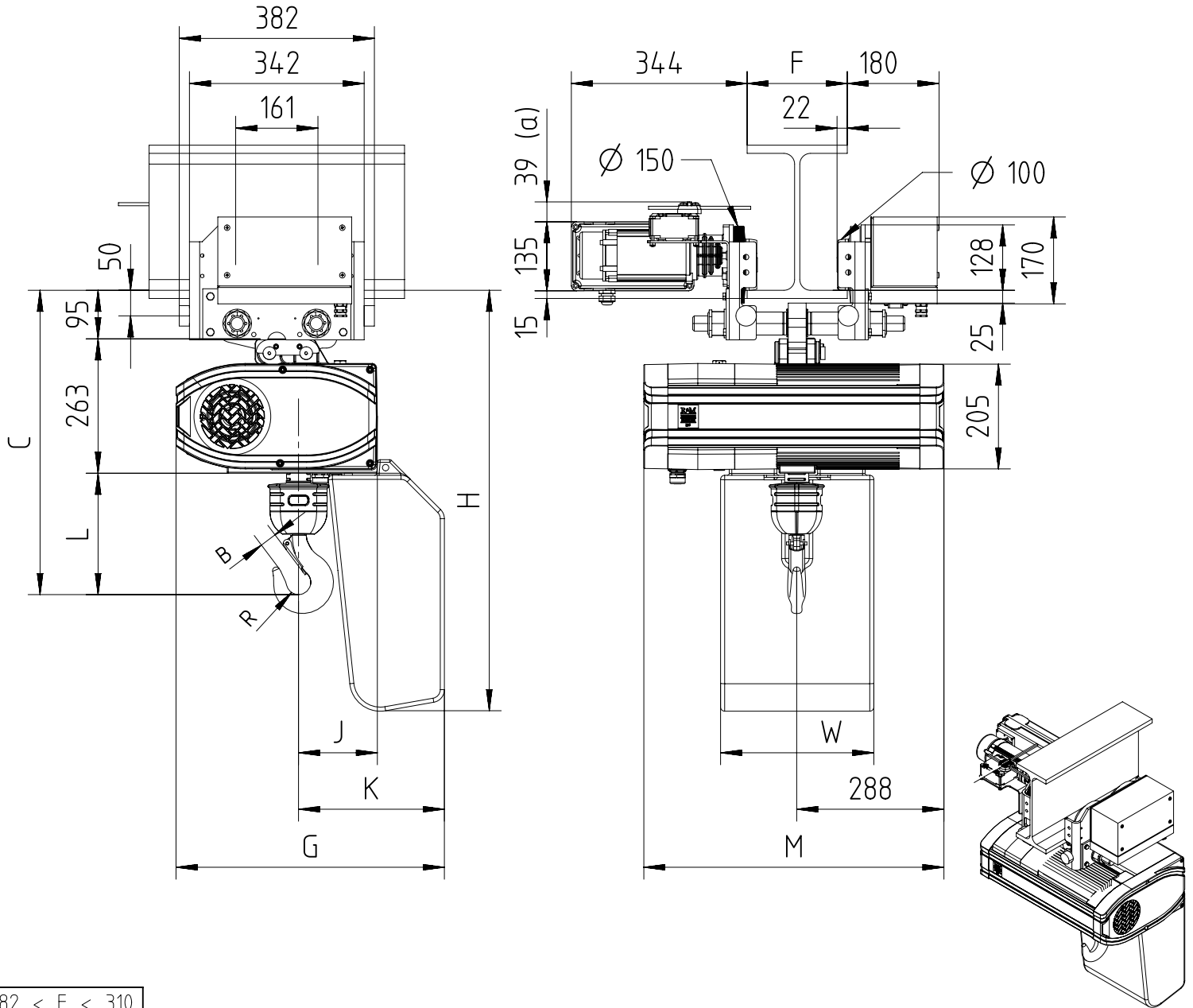

$82 < F < 310$

(a) Note: Trolley limit switch is optional.
 Note: In case of 2-fall hoist, coupling suspension is rotated by 180°.
 Note: Mini. radius of curve for trolley 3200 Kg is 2m.
 Note: Add 60mm to C & L dimension for hoisting speeds greater than 8 m/min.

Chain Size (mm)	Max load (Kg)	Falls	Chain bag capacity (m)	Dimensions (mm)											Weight of chain (kg/m)	Estimated weight of hoist incl. trolley w/o chain (Kg)			
				B	C	L	R	J	K	G	H	W	M			LK	GLS	DB	
													LK/	GLS					DB
11.3X31	2500	1	12	33	596	238	24	154	286	525	824	300	587	709	2.8	159	164	165	
			30 (*)						443	682	945								
	3200	2	12 (**)	41	696	388	28	203	334	525	824	300	587	709	2.8	163	168	169	
			30 (*, **)						494	682	945								

GLS: Gear Limit Switch
 DB : Double Brake
 (*) For big height of lift, customer has to link the chain bag to the structure.
 (**) In case of 2-fall hoist, available lifting height is half of the chain bag maximum capacity.

R&M reserves the right to alter or amend the above information without notice.

DISCLOSED WITHOUT PRIOR WRITTEN CONSENT OF THE COMPANY . ANY COPIES OF THIS DOCUMENT MADE BY ANY METHOD MUST ALSO INCLUDE A COPY OF THIS LEGEND.