

# LR ELECTRIC CHAIN HOIST

Our new LR chain hoist is built to last, with features that make your job easier. Built smart with the toughness, precision and reliability of our Core of Lifting components, it is designed and tested for more than a million operations over the designed working period of the hoist. As one of the most economical hoists available in the market and a broad range of standard features, the LR hoist brings you industry-leading value to performance ratio. It is everything you want and need for efficiency, safety and productivity.



# RISE ABOVE™

# LR ELECTRIC CHAIN HOIST

The LR chain hoist features a reimagined motor design that runs cooler so it can run longer, making your business more productive. Innovative technology and optimized mechanics take reliability to a whole new level.



## LR ELECTRIC CHAIN HOIST STANDARD FEATURES

- 1/8 - 2 ton (125 - 2000 kg) capacities
- Zinc plated and case-hardened load chain (DAT) 10, 15 and 20 ft (3, 4.5 and 6 m) standard lift heights
  - Additional lift available in 1 ft or 1/2 m increments
- U-shaped bracket suspension connects to a wide range of trolley types for monorails, enclosed track or other fixing points
- Two-speed hoist controls (4:1 speed ratio) - available for various power supplies
- Single speed hoist controls - available for 460V-3Ph-60Hz power supply only
- Upper and lower electrical limit (micro) switches
- Torque-limiting slip clutch device for hoist overload protection
- Plug-in pushbutton pendant with E-stop button
- Indoor use - operational temperature with rated load and speed: -4°F to 104°F [-20°C to 40°C]
- Durable, injection-molded chain container is included



### Built-In Overheating Protection

Highly efficient motor fan and large motor fins ensure constant airflow and optimum motor cooling.



### Geared Up for Performance

Helical gearing for quiet and efficient operation, gearbox lubrication designed to last for the safe working period of the hoist - enhancing performance and reducing maintenance downtime.

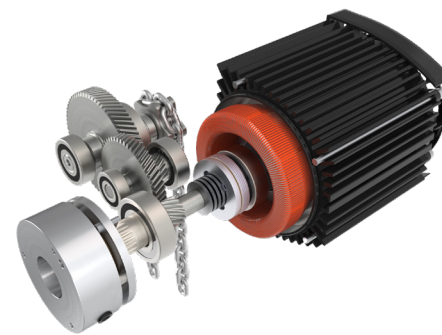

### Patented Slip Clutch Design

Patented design protects against overloading, enables easy access for service and adjustments and provides outstanding safety and reliability.



### Safe & Efficient Braking

Safe brake position prevents hook slippage, and optimized torque reduces shock loading and stress on gearing - leading to long service life for lower-cost operation.



### Optimized Chain Drive

Featuring rugged, case-hardened chain for long service life, even in high duty-cycle applications, and 5 or 6 pocket chain wheel options for smooth operations. Safe and reliable upper and lower limit switches included as standard.



# WELCOME TO THE NEXT GENERATION OF CHAIN HOISTS

With its rugged, efficient and innovative design, the LR electric chain hoist is built to last, offering outstanding value. Every feature has been engineered to provide efficiency and safety at an economical price point. From our innovative design and rigorous testing, to the ease of installation and operation, the LR electric chain hoist brings more power for your lifting.

- Rugged, innovative design offers outstanding price-to-performance ratio
- Revolutionary U-shaped top suspension bracket design that works as a hook or lug mounted connection and reduces the headroom of the hoist
- Rugged, case-hardened chain and precision-made chain drive system increase chain life and reduce maintenance costs
- Built-in overheating protection prevents damage to critical components

## VERSATILITY FOR INDUSTRIAL APPLICATIONS

Compact headroom, a suspension bracket and a range of other features make LR chain hoists easily adjustable to your specific workstation needs.

### Manual or Motorized Beam Trolleys

- Adjustable for flange widths of 2.28 in - 12.20 in (58 mm - 310 mm)
- Smooth rolling manual trolley for ease of movement
- Reliable motorized trolley travel in two-speed or inverter driven control types for maximum operator comfort
- Optional travel limit switch available

### Installation Made Easy

The LR chain hoist's innovative U-shaped suspension bracket can be used as a lug mounted or hook connection, making installation fast and easy – no special tools are needed.

- Safe and secure locking pins
- Compatible with a large variety of trolleys and fixed suspension applications
- Hoist remains perfectly balanced
- Low headroom design

# SAFETY FEATURES

Safety is critical to any industrial operation. Upper and lower limit switches keep you safe and protect your equipment by preventing overtravel of the hook and chain. The LR hoist also comes with order-specific parts, maintenance and safety manuals, so you won't have to guess whether you are following the correct guidelines.

## INNOVATIVE PERFORMANCE WITH EASY SERVICE

- Gearbox lubrication that's designed to last
- Plug-and-play electrical components
- Easy-to-access service and inspection points
- Improved chain life with case-hardened DAT chain

## HIGH-PERFORMANCE MOTOR

- Heavy duty type 60% ED (CDF) rating (exceeds 30 min. rating) on three-phase motors
- IP55 protection; Class F Insulation
- 4:1 speed ratio for precision load handling

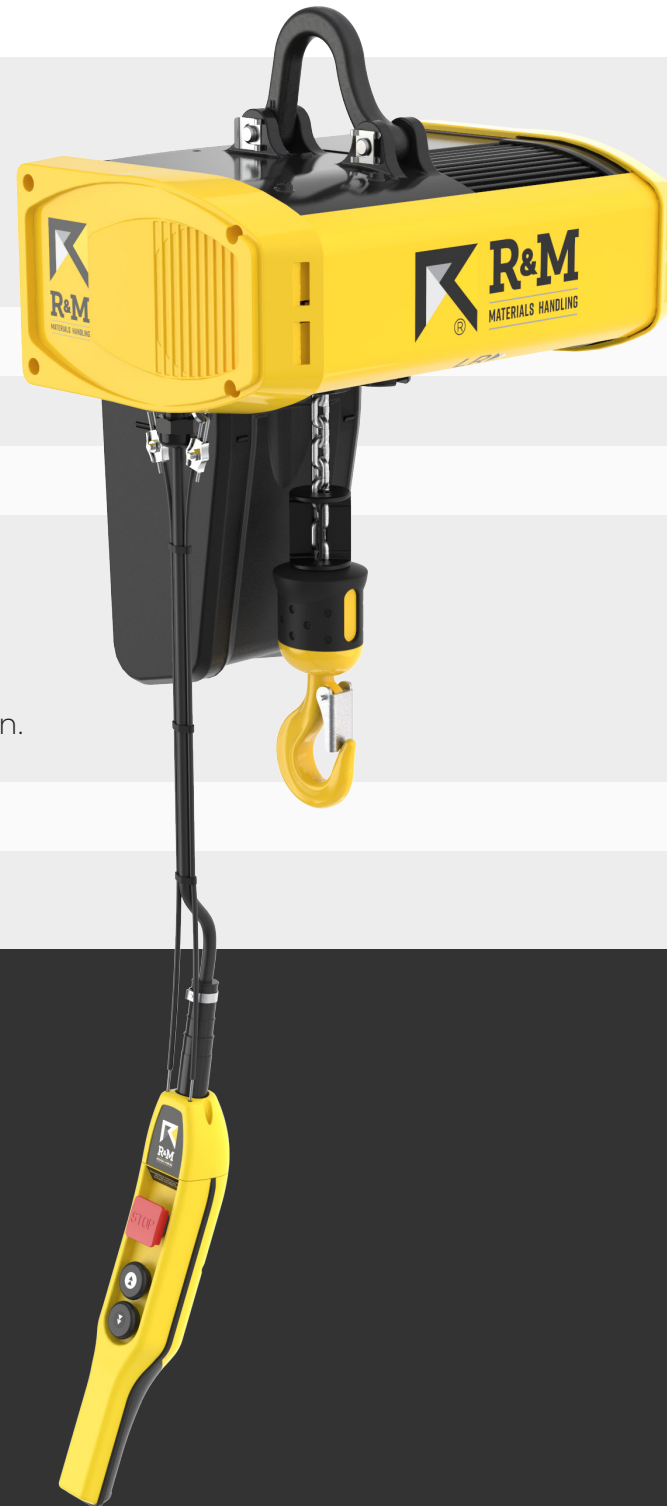

## LOAD WHEEL

LR hoists are fitted with a unique patented chain drive system featuring a precision-cut 5- or 6-pocket load wheel to reduce stress and maintenance needs on the chain. This makes the hoist motion smooth and quiet when operating and works with case-hardened chain to reduce chain wear.

## FRAME SIZES & CAPACITY RANGES

Capacity Range - Tons (kg)	Frame Size	Chain Falls
1/8 - 1/4 ton (125 - 250 kg)	LR02	1
1/4 - 1/2 ton (250 - 500 kg)	LR02	2
1/8 - 1/2 ton (160 - 500 kg)	LR05	1
1/2 - 1 ton ( 500 - 1000 kg)	LR05	2
1/2 - 1 1/4 ton (500 - 1250 kg)	LR10	1
1 1/4 - 2 ton (1250 - 2000 kg)	LR10	2

Our LR hoists are factory load tested at 125% of the rated capacity and have a patented slip clutch design that protects against overload.

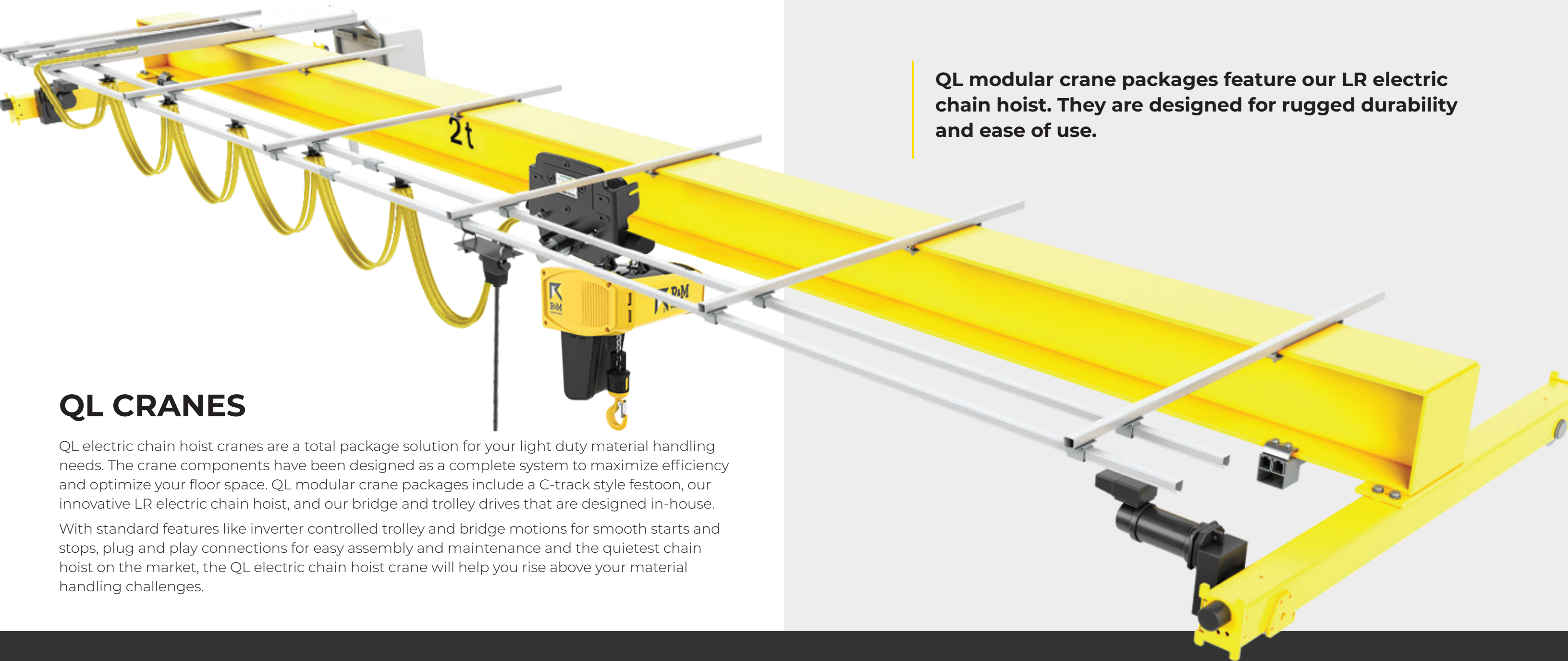

QL modular crane packages feature our LR electric chain hoist. They are designed for rugged durability and ease of use.

## QL CRANES

QL electric chain hoist cranes are a total package solution for your light duty material handling needs. The crane components have been designed as a complete system to maximize efficiency and optimize your floor space. QL modular crane packages include a C-track style festoon, our innovative LR electric chain hoist, and our bridge and trolley drives that are designed in-house.

With standard features like inverter controlled trolley and bridge motions for smooth starts and stops, plug and play connections for easy assembly and maintenance and the quietest chain hoist on the market, the QL electric chain hoist crane will help you rise above your material handling challenges.

## PRECISION LOAD HANDLING

The crane is equipped with all inverter controlled trolley and bridge motions, meaning reduced load swing and better safety. The inverter controls also significantly reduce brake wear on the trolley and bridge. Every LR electric chain hoist comes standard with our innovative slip clutch overload device, protecting you from dangerous accidental overloads. With the slip clutch device, if an operator attempts to lift a load beyond the rated capacity, the load will only be able to lower safely to the ground.

### STANDARD FEATURES

- LR electric chain hoist with two-speed hoisting controls
- 1/2 - 5 ton (500 - 5,000 kg) capacities
- Single girder top running or single girder underrunning crane designs
- Standard inverter controls for trolley and bridge for reduced load swing
- Durable C-track festoon system with UL listed cables
- LR electric chain hoist with motorized trolley
- 208, 230, 460 or 575/3/60 power supplies
- Crane spans up to 62 ft [19m]
- PRQ ergonomic pendant controller
- Optional RaCon® ARC radio controller
- CSA C/US approved NEMA 4-3R type/IP55

# QLP PUSH CRANES

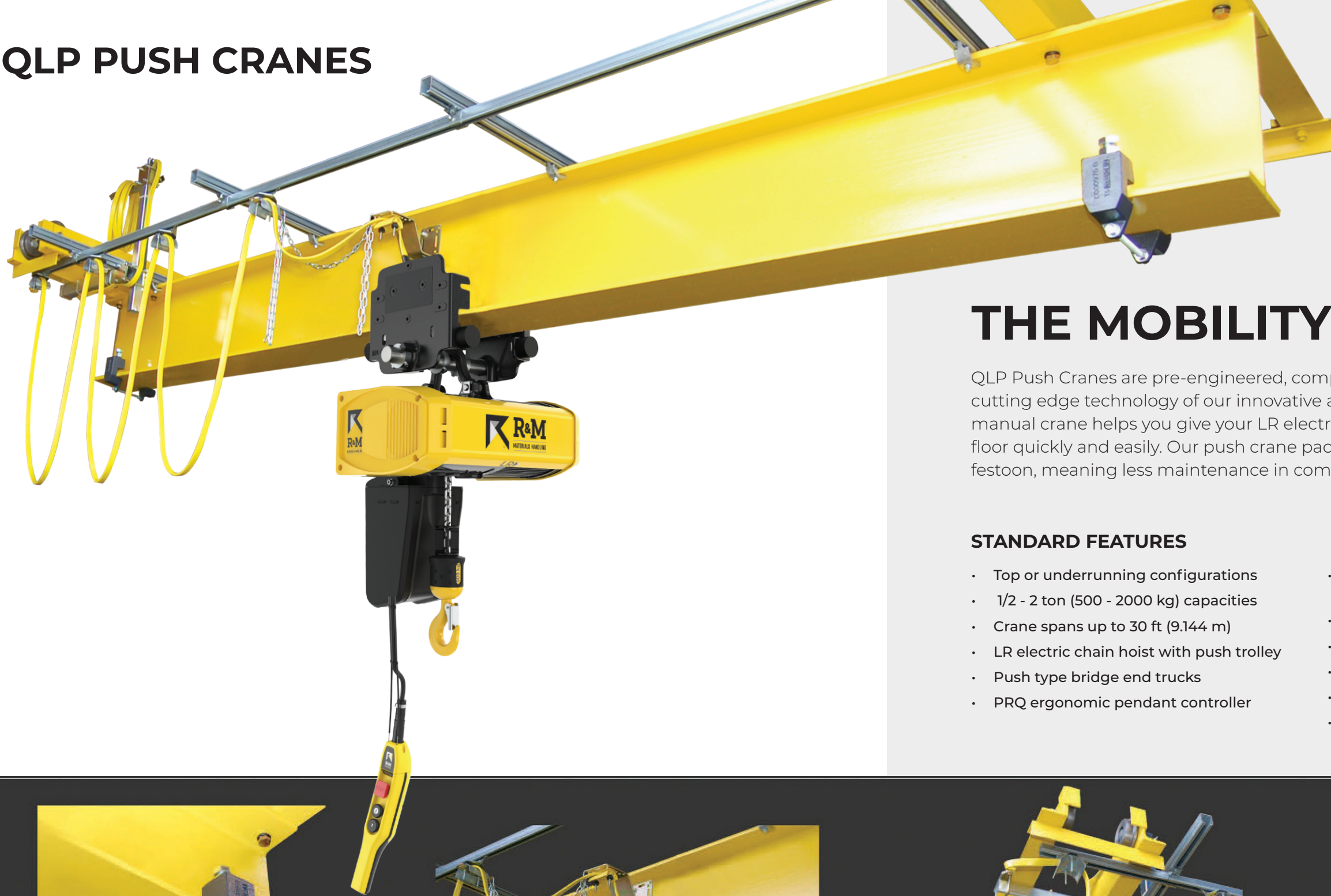

## THE MOBILITY YOU NEED

QLP Push Cranes are pre-engineered, complete crane component packages utilizing the cutting edge technology of our innovative and rugged LR electric chain hoist. A push-pull manual crane helps you give your LR electric chain hoist the mobility to cover your shop floor quickly and easily. Our push crane packages are designed with a plug-and-play C-track festoon, meaning less maintenance in comparison to the traditional tag line power supply.

### STANDARD FEATURES

- Top or underrunning configurations
- 1/2 - 2 ton (500 - 2000 kg) capacities
- Crane spans up to 30 ft (9.144 m)
- LR electric chain hoist with push trolley
- Push type bridge end trucks
- PRQ ergonomic pendant controller
- C-track style power festoon for industry-leading durability
- Bolt-on end stops for the hoist trolley
- Optional crane tow arm
- IP55 protection rating for indoor service
- Meets CMAA and FEM standards
- CSA C/US approved NEMA 4-3R type/IP55

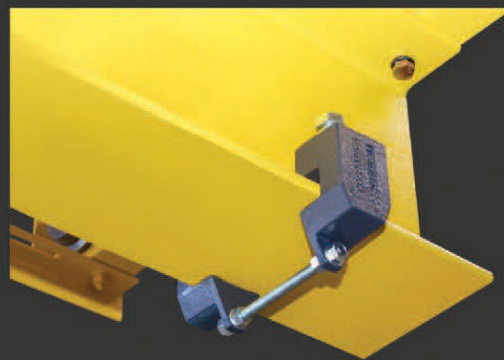

### END STOPS

Included bolt-on end stops for the hoist trolley



### TOW ARM

Optional crane tow arm



### FESTOON

Comes complete with a plug-and-play power cable, galvanized C-track and cable trolleys

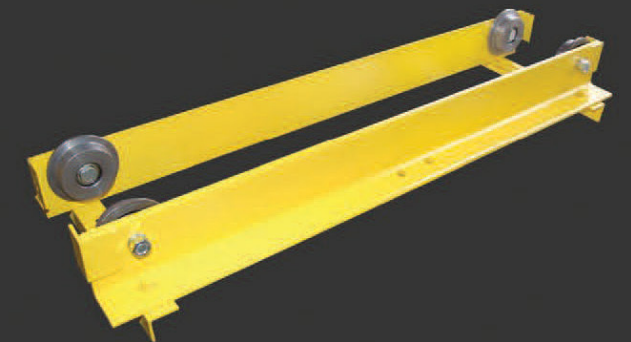

### END TRUCKS

Fully assembled end trucks featuring pre-lubricated, antifriction wheel bearings and mandatory safety lugs



## RISE ABOVE WITH R&M MATERIALS HANDLING, INC.

R&M has been innovating since 1929. With our heritage of innovation, our wire rope and chain hoist products have consistently set the crane industry norms. Our cutting-edge solutions will help you to rise above your material handling challenges. You deserve the best performance possible; let us help you achieve it!

R&M Materials Handling, Inc. may alter or amend the technical specifications identified herein at any time with or without notice.  
R&M Materials Handling, Inc. is a proud member of the following organizations:



R&M Materials Handling, Inc. | 4400 Gateway Boulevard, Springfield, Ohio 45502 | 1-800-955-9967  
www.rmhoist.com | © 2024 R&M Materials Handling, Inc. | Bulletin #LR 05/08/2024