

NORMAL HEADROOM, CURVED TRACK, 2 PART DOUBLE

Hoist type:

SX5 022...N0

SI-60Hz

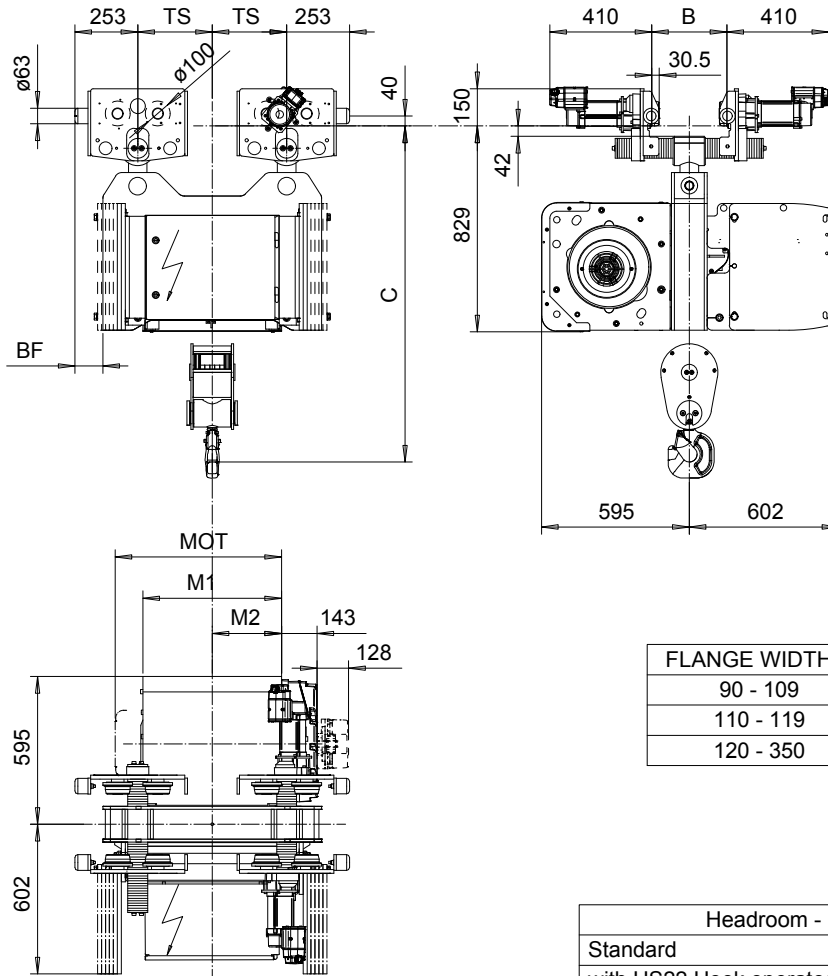

FLANGE WIDTH B	R min
90 - 109	2500
110 - 119	2000
120 - 350	1500

Headroom - C dimension	
Standard	1353 mm
with HS22 Hook operated limit switch	1403 mm

Motor	P5	P6	P7	A5	S5	S7
MOT (mm)	578	578	618	498	606	757
Weight (kg)	58	85	105	45	53	81

Load (kg)	Class
	Fem/ISO
4000	3m/M6
5000	2m/M5

HOL	Length (m)	H1 (mm)	M1 (mm)	M2 (mm)	BF (mm)	TS (mm)	Approx. Weight (kg)
	code	(mm)	(mm)	(mm)	(mm)	(mm)	(kg)
8.5	D	553	558	279	113	300	890
13	E	553	678	339	113	300	945
18	F	553	828	414	113	300	1000
25	G	753	1018	509	-77	500	1145
33.5	H	753	1268	634	-77	500	1215
46	J	753	1618	809	-77	500	1330

Approx. Weight calculated with P5 motor.

This document is the absolute property of R&M Materials Handling, Inc. This document must not be copied without the written permission of R&M Materials Handling, Inc. The contents thereof must not be disclosed to a third party nor be used for any unauthorized purpose. Contravention will be prosecuted.

ETVPH Design	ETVPH Chk	Appt	Ref Drawing	QC-N-22
2005-08-26 Date	TROLLEY; NORMAL HEADROOM			1:13
SLEQDQCV Drawn/Dept	CURVED TRACK, 2x2 ROPE FALLS			Folder
R&M MATERIALS HANDLING INC.	R&M MATERIALS HANDLING, INC HOIST & CRANE PRODUCTS SPRINGFIELD, OHIO			Issue 1
D007220-A				