

# NORMAL HEADROOM, 4 PART DOUBLE

Hoist type:

SX5 042...N0

SI-60Hz

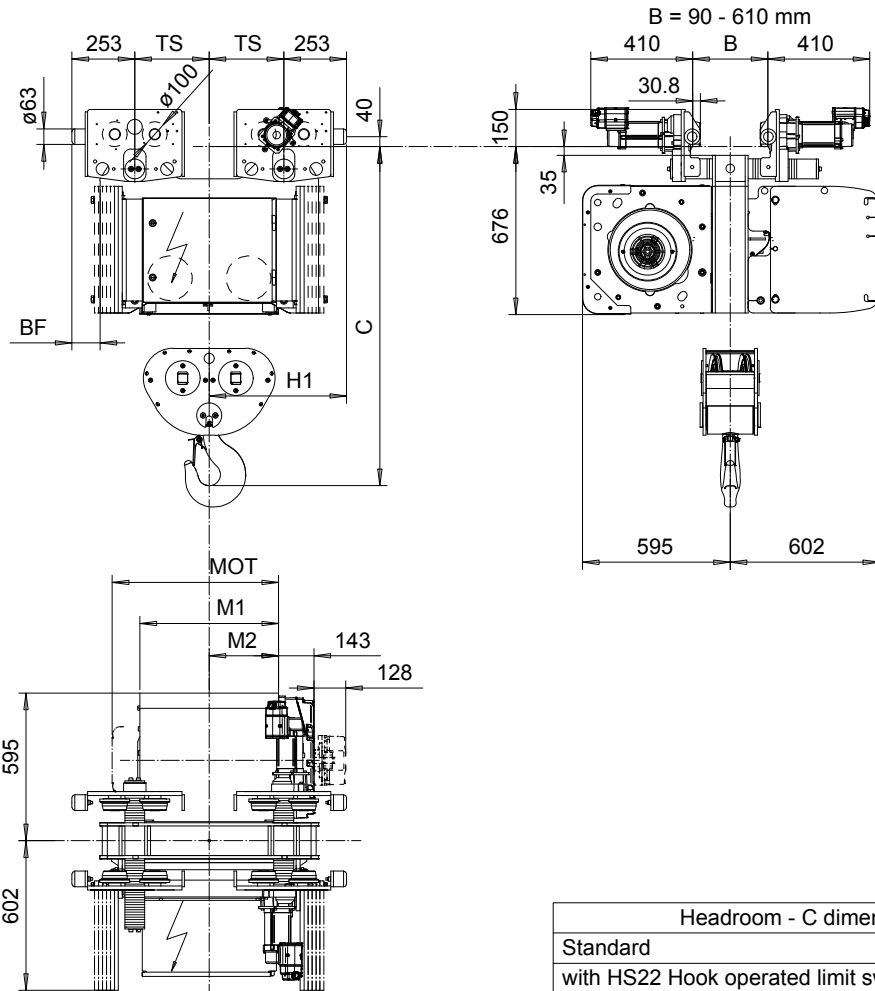

Headroom - C dimension	
Standard	1365 mm
with HS22 Hook operated limit switch	1415 mm

Motor	P5	P6	P7	A5	S5	S7
MOT (mm)	578	578	618	498	606	757
Weight (kg)	58	85	105	45	53	81

Load (kg)	Class Fem/ISO
6300	3m/M6
8000	3m/M6
10000	2m/M5

HOL (m)	Length code	H1 (mm)	M1 (mm)	M2 (mm)	BF (mm)	TS (mm)	Approx. Weight (kg)
4	D	553	558	279	113	300	950
6.5	E	553	678	339	113	300	970
9	F	553	828	414	113	300	1020
12.5	G	753	1018	509	-77	500	1165
16.5	H	753	1268	634	-77	500	1240
23	J	753	1618	809	-77	500	1325

Approx. Weight calculated with P5 motor.  
 Brake mounted on gearcase cover for Length code H and J.

This document is the absolute property of R&M Materials Handling, Inc. This document must not be copied without the written permission of R&M Materials Handling, Inc. The contents thereof must not be disclosed to a third party nor be used for any unauthorized purpose. Contravention will be prosecuted.

ETVPH Design	ETVPH Chd	Appt	Ref Drawing	QC-N-24
2005-08-26 Date	TROLLEY; NORMAL HEADROOM			1:13
SLEQDQCV Drawn (Date)	2x4 ROPE FALLS			Folder
R&M MATERIALS HANDLING INC.	R&M MATERIALS HANDLING, INC. HOIST & CRANE PRODUCTS SPRINGFIELD, OHIO	D007221-A		Issue 1