

NORMAL HEADROOM, 6 PART SINGLE

Hoist type:

SX5 061...N0

SI-50Hz

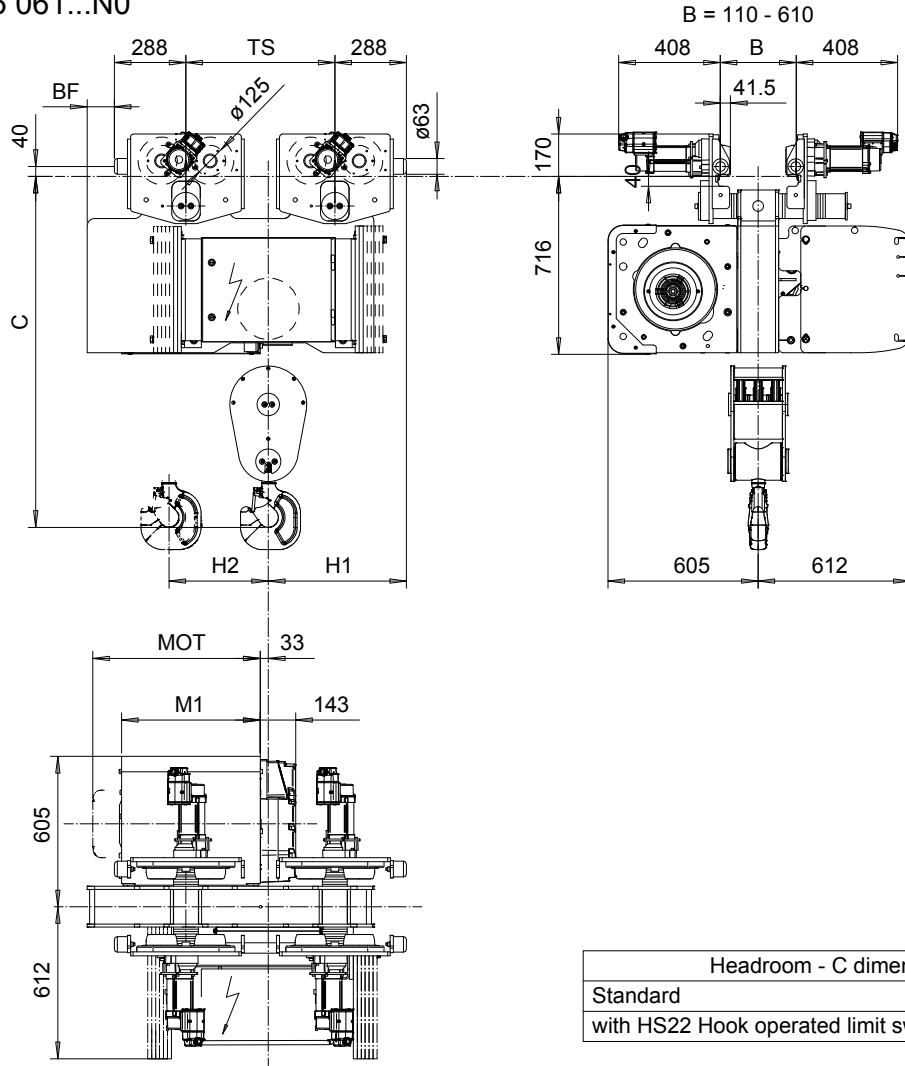

Headroom - C dimension	
Standard	1413 mm
with HS22 Hook operated limit switch	1463 mm

Motor	P5	P6	P7	A5	S5	S7
MOT (mm)	578	578	618	498	606	757
Weight (kg)	58	85	105	45	53	81

Load (kg)	Class Fem/ISO
12000	3m/M6
15000	2m/M5

HOL (m)	Length code	M1 (mm)	BF (mm)	TS (mm)	H1 (mm)	H2 (mm)	Approx. Weight (kg)
6	D	558	110	600	556	53	1030
8	E	678	110	600	556	78	1050
10	F	828	370	720	596	98	1140
13	G	1018	370	720	596	132	1195

Approx. Weight calculated with P5 motor.

This document is the absolute property of R&M Materials Handling, Inc. This document must not be copied without the written permission of R&M Materials Handling, Inc. The contents thereof must not be disclosed to a third party nor be used for any unauthorized purpose. Contravention will be prosecuted.

ETVPH Design	ETVPH Chk	Appt	Ref Drawing	QC-N-06
2005-08-26 Date	TROLLEY; NORMAL HEADROOM			1:13
SLEQDQCV Drawn (Dept)	6 ROPE FALLS			Folder
R&M MATERIALS HANDLING INC.	R&M MATERIALS HANDLING, INC. HOIST & CRANE PRODUCTS SPRINGFIELD, OHIO			Issue 1
D007206-A				