

FOOT MOUNT, 6 PART DOUBLE

Hoist type:

SX5 062...F0

SI-50Hz

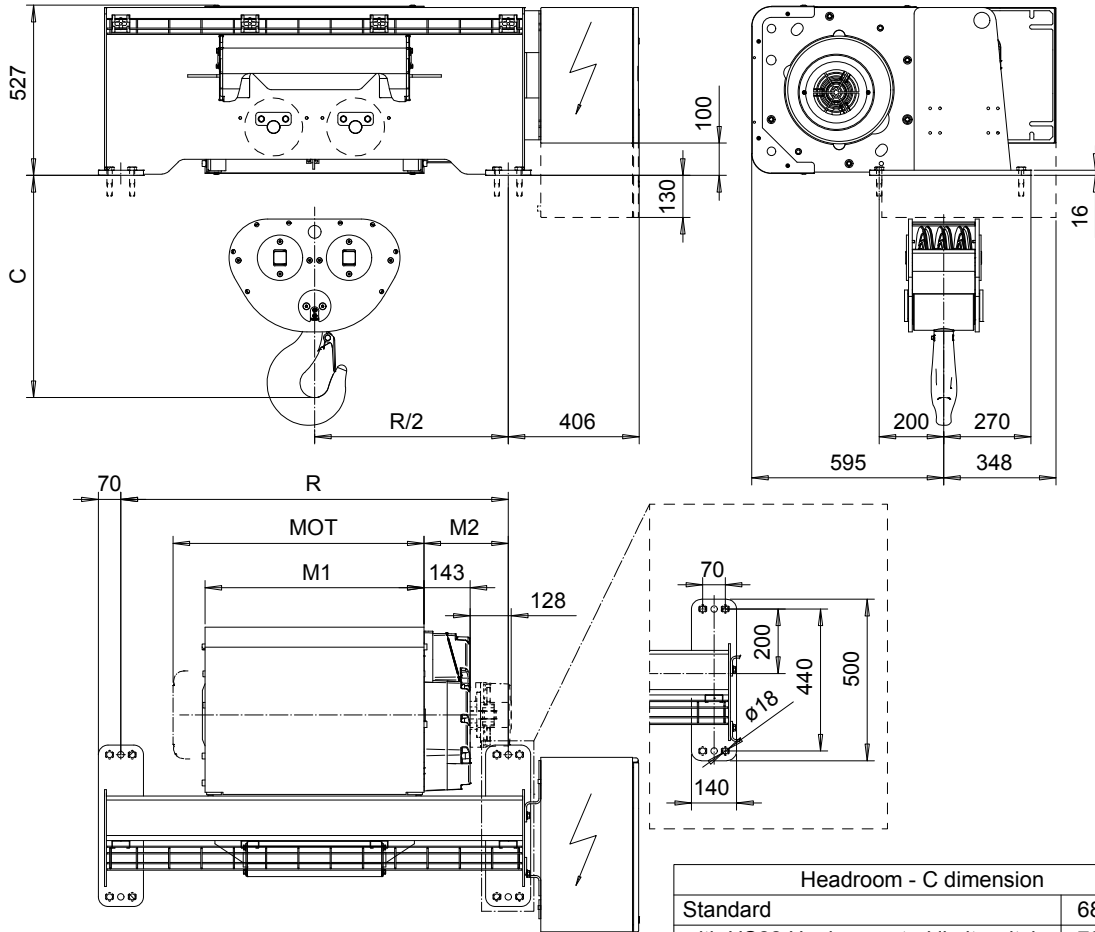

Headroom - C dimension	
Standard	688 mm
with HS22 Hook operated limit switch	738 mm

Motor	P5	P6	P7	A5	S5	S7
MOT (mm)	578	578	618	498	606	757
Weight (kg)	58	85	105	45	53	81

Load (kg)	Class Fem/ISO
12000	3m/M6
15000	2m/M5

HOL (m)	Length code	M1 (mm)	M2 (mm)	R (mm)	Approx Weight (kg)
4	E	678	261	1200	600
6	F	828	186	1200	625
8	G	1018	91	1200	665
11	H	1268	216	1700	745
15	J	1618	191	2000	830

Brake is mounted on gearcase for drum length H and J.
 Approx weight calculated with P5 motor.

This document is the absolute property of R&M Materials Handling, Inc. This document must not be copied without the written permission of R&M Materials Handling, Inc. The contents thereof must not be disclosed to a third party nor be used for any unauthorized purpose. Contravention will be prosecuted.

ETTPAL Design	ETTPAL Chd	Appd	Ref Drawing	QC-F-26
2002-08-30 Date	HOIST; FIXED			
SLEODOCV Owner Dept	2x6 ROPE FALLS			
R&M MATERIALS HANDLING INC.	R&M MATERIALS HANDLING, INC. HOIST & CRANE PRODUCTS SPRINGFIELD, OHIO	D007246-A		Issue 2