

FOOT MOUNT, 6 PART DOUBLE

Hoist type:

SX5 062...F0

US-60Hz

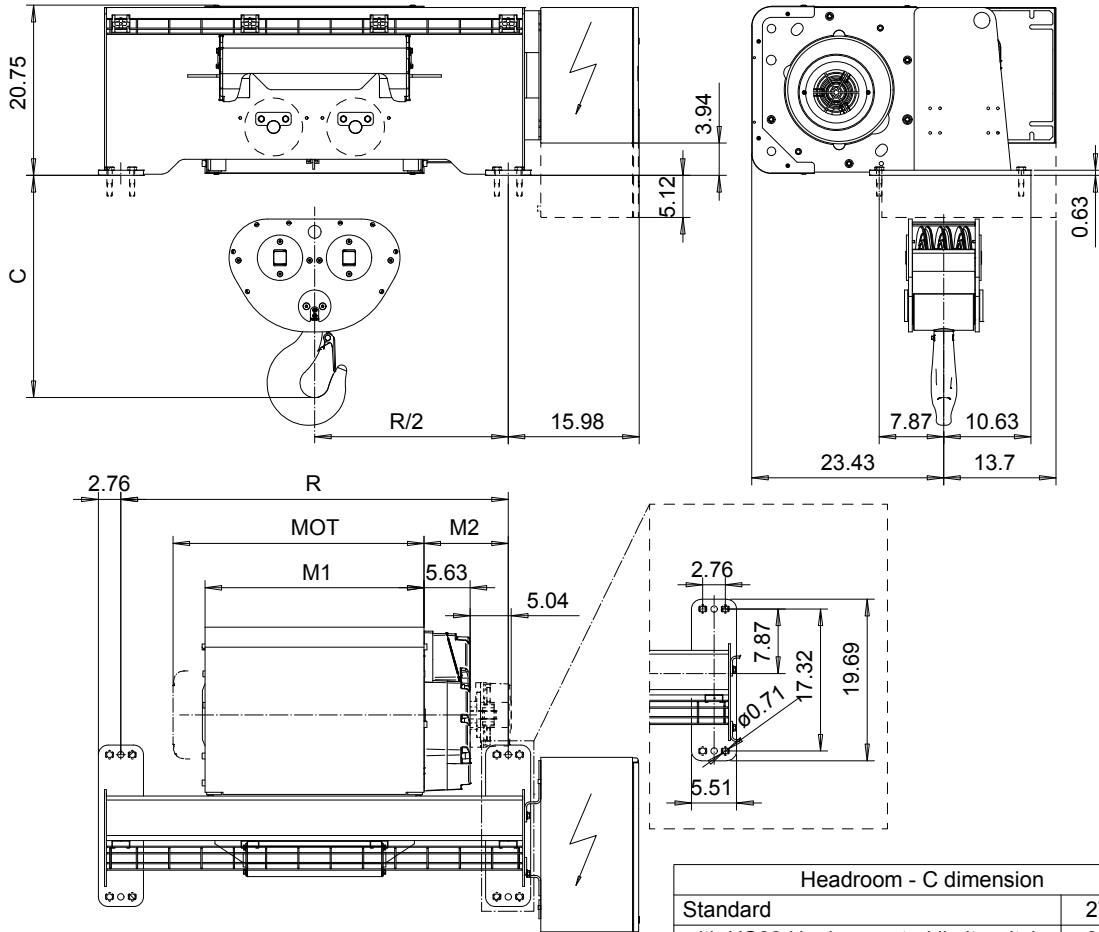

Headroom - C dimension	
Standard	27.09"
with HS22 Hook operated limit switch	29.09"

Motor	P5	P6	P7	A5	S5	S7
MOT (in)	22.76	22.76	24.33	19.61	23.86	29.8
Weight (lb)	128	187	231	99	117	179

Load (TON)	Class ASME
12	H4+
15	H4

HOL (ft)	Length code	M1 (inch)	M2 (inch)	R (inch)	Weight (lb)
13'-1"	E	26.69	10.28	47.25	1323
19'-8"	F	32.6	7.32	47.25	1378
26'-2"	G	40.09	3.58	47.25	1466
36'-1"	H	49.92	8.50	66.93	1642
49'-2"	J	63.7	7.52	78.74	1830

Brake is mounted on gearcase for drum length H and J.
 Approx weight calculated with P5 motor.

This document is the absolute property of R&M Materials Handling, Inc. This document must not be copied without the written permission of R&M Materials Handling, Inc. The contents thereof must not be disclosed to a third party nor be used for any unauthorized purpose. Contravention will be prosecuted.

ETTPAL Design	ETTPAL Chd	Appd	Ref Drawing	QC-F-26
2002-08-30 Date	HOIST; FIXED			
SLEODOCV Owner Dept	2x6 ROPE FALLS			
R&M MATERIALS HANDLING INC.	R&M MATERIALS HANDLING, INC. HOIST & CRANE PRODUCTS SPRINGFIELD, OHIO	D007246-A		Issue 2