

**NORMAL HEADROOM, 6 PART DOUBLE**  
**Hoist type:**  
**SX5 062...N0**

SI-60Hz

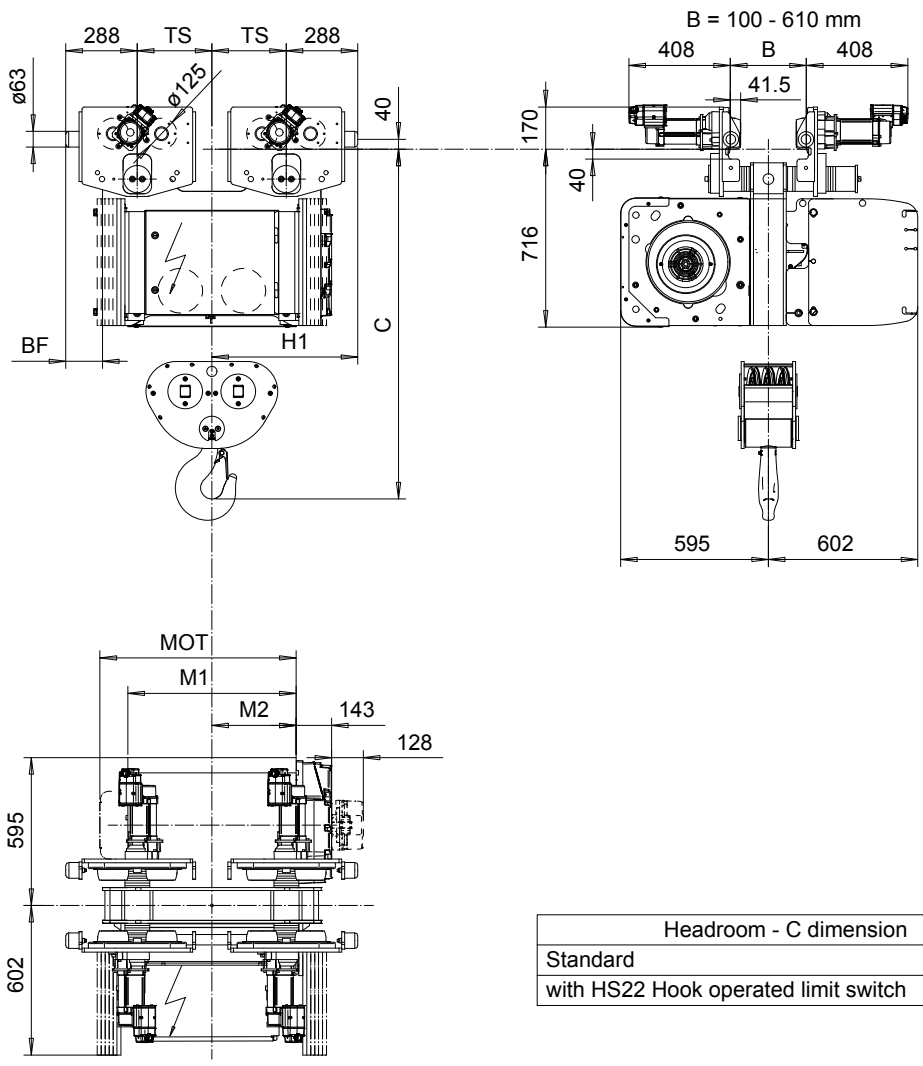

Headroom - C dimension	
Standard	1408 mm
with HS22 Hook operated limit switch	1458 mm

Motor	P5	P6	P7	A5	S5	S7
MOT (mm)	578	578	618	498	606	757
Weight (kg)	58	85	105	45	53	81

Load (kg)	Class Fem/ISO
12000	3m/M6
15000	2m/M5

HOL (m)	Length code	H1 (mm)	M1 (mm)	M2 (mm)	BF (mm)	TS (mm)	Approx. Weight (kg)
4	E	588	678	339	148	300	990
6	F	588	828	414	148	300	1010
8	G	788	1018	509	-42	500	1060
11	H	788	1268	634	-42	500	1205
15	J	788	1618	809	-42	500	1280

Approx. Weight calculated with P5 motor.  
 Brake mounted on gearcase cover for Length code H and J.

This document is the absolute property of R&M Materials Handling, Inc. This document must not be copied without the written permission of R&M Materials Handling, Inc. The contents thereof must not be disclosed to a third party nor be used for any unauthorized purpose. Contravention will be prosecuted.

ETVPH Design	ETVPH Chd	Appt	Ref Drawing	QC-N-26
2005-08-26 Date	TROLLEY; NORMAL HEADROOM			1:13
SLEQDQCV Drawn (App)	2x6 ROPE FALLS			Folder
R&M MATERIALS HANDLING INC.	R&M MATERIALS HANDLING, INC HOIST & CRANE PRODUCTS SPRINGFIELD, OHIO	D007223-A		Issue 1