

# NORMAL HEADROOM, CURVED TRACK, 6 PART DOUBLE

Hoist type:

SX5 062...N0

SI-50Hz

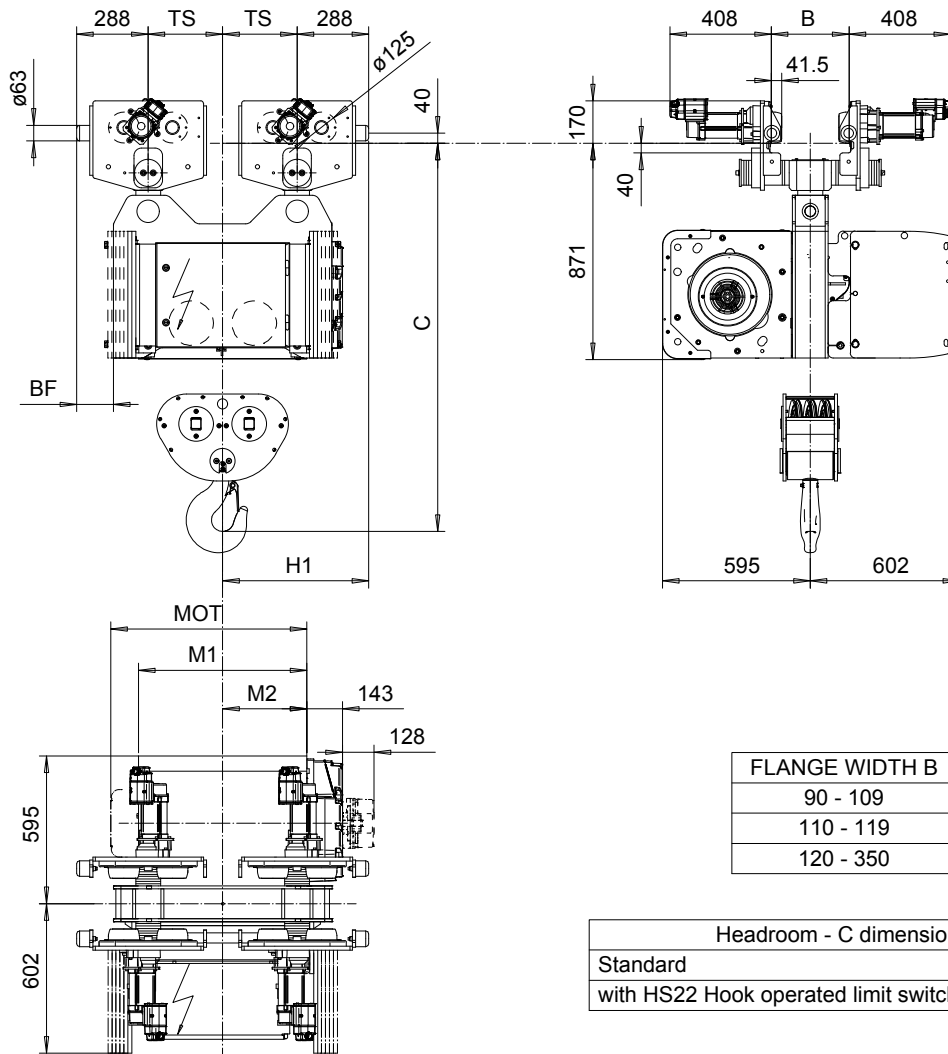

FLANGE WIDTH B	R min
90 - 109	2500
110 - 119	2000
120 - 350	1500

Headroom - C dimension	
Standard	1563 mm
with HS22 Hook operated limit switch	1613 mm

Motor	P5	P6	P7	A5	S5	S7
MOT (mm)	578	578	618	498	606	757
Weight (kg)	58	85	105	45	53	81

Load (kg)	Class Fem/ISO
12000	3m/M6
15000	2m/M5

HOL (m)	Length code	H1 (mm)	M1 (mm)	M2 (mm)	BF (mm)	TS (mm)	Approx. Weight (kg)
4	E	588	678	339	148	300	1115
6	F	588	828	414	148	300	1165
8	G	788	1018	509	-42	500	1310
11	H	788	1268	634	-42	500	1385
15	J	788	1618	809	-42	500	1495

Approx. Weight calculated with P5 motor.

This document is the absolute property of R&M Materials Handling, Inc. This document must not be copied without the written permission of R&M Materials Handling, Inc. The contents thereof must not be disclosed to a third party nor be used for any unauthorized purpose. Contravention will be prosecuted.

ETTVPH Design	ETTVPH Cnd	Appt	Ref Drawing	QC-N-06
2005-08-26 Date	TROLLEY; NORMAL HEADROOM			1:13
SLEQDQCV Owner/Dept	CURVED TRACK, 2x6 ROPE FALLS			Folder
R&M MATERIALS HANDLING INC.	R&M MATERIALS HANDLING, INC HOIST & CRANE PRODUCTS SPRINGFIELD, OHIO			Issue 1
D007224-A				