

**FOOT MOUNT, 8 PART SINGLE**  
Hoist type:  
SX5 081...F0

SI-60Hz

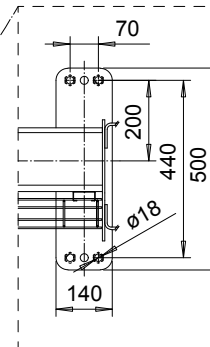
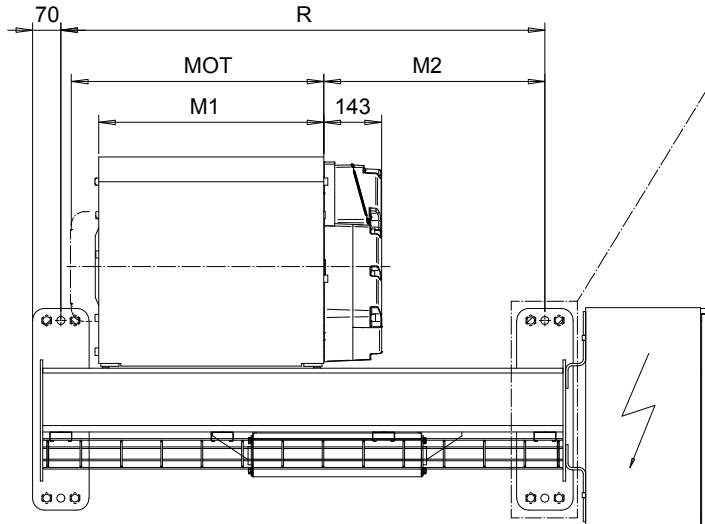
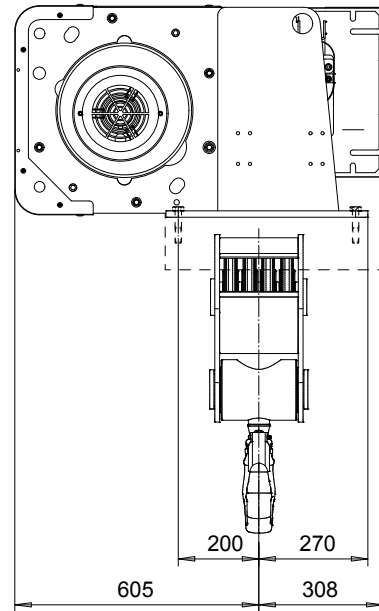
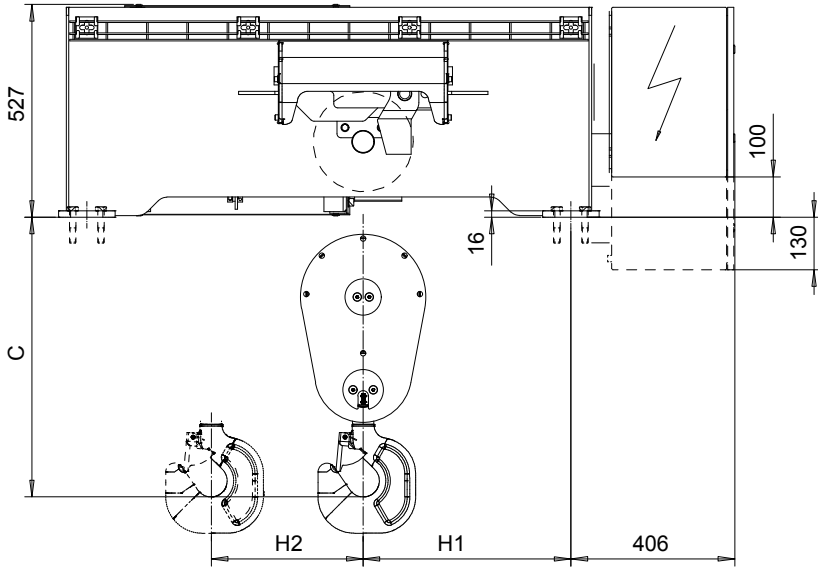

Headroom - C dimension	
Standard	693 mm
with HS22 Hook operated limit switch	743 mm

Motor	P5	P6	P7	A5	S5	S7
MOT (mm)	578	578	618	498	606	757
Weight (kg)	58	85	105	45	53	81

Load (kg)	Class Fem/ISO
16000	2m/M5
20000	1Am/M4

HOL (m)	Length code	M1 (mm)	M2 (mm)	R (mm)	H1 (mm)	H2 (mm)	Approx. Weight (kg)
4.5	D	558	548	1200	515	44	600
6	E	678	628	1400	595	53	635
8	F	828	778	1700	745	76	690
10	G	1018	888	2000	855	98	750

Approx weight calculated with P5 motor

This document is the absolute property of R&M Materials Handling, Inc. This document must not be copied without the written permission of R&M Materials Handling, Inc. The contents thereof must not be disclosed to a third party nor be used for any unauthorized purpose. Contravention will be prosecuted.

ETTPAL Design 2002-08-30 Date	ETTPAL Chd Appd	Ref Drawing	QC-F-08
SLEODOCV Owner Dept	HOIST; FIXED 8 ROPE FALLS		1:8 Folder
R&M MATERIALS HANDLING INC.	R&M MATERIALS HANDLING, INC HOIST & CRANE PRODUCTS SPRINGFIELD, OHIO	D007243-A	Issue 2