

DOUBLE GIRDER, MEDIUM, 2 PART SINGLE
Hoist type:
SX6 021...D0

SI-50Hz

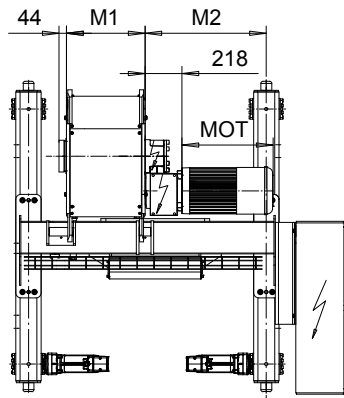
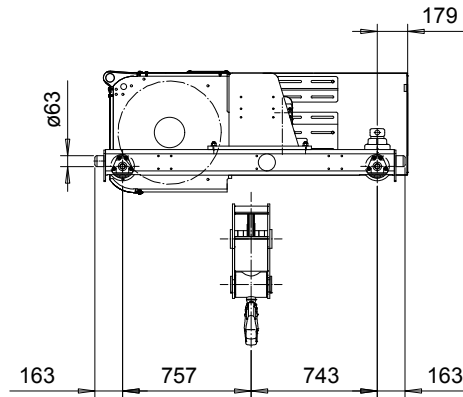
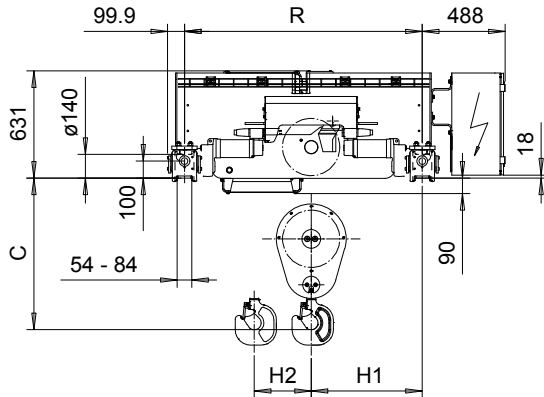

HOL	HOL*	Length	M1	M2	H1	H2	Min R	Max R	Approx Weight
(m)	(m)	code	(mm)	(mm)	(mm)	(mm)	(mm)	(mm)	(kg)
15.5	10	C	462	714	654	139	1400	1400	1250
21	15.5	D	562	799	739	188	1700	2700	1320
28	22.5	E	682	799	739	251	1700	3100	1370
36	30.5	F	832	949	889	322	2000	3100	1460
47	41.5	G	1022	1149	1089	421	2400	3100	1570
61	55.5	H	1272	1469	1409	546	3100	3800	1750
80.5	75	J	1622	1559	1499	721	3400	4200	1950
97	91.5	K	1922	1944	1884	868	4200	4200	2200

HOL* with optional drum brake Weight of drum brake is 80 kg.

Motor	P6	P7	P8	A7	S7	S8	SA
MOT (mm)	536	576	711	536	715	763	803
Weight (kg)	85	105	106	71	81	97	120

Load	Class
(kg)	Fem/ISO
6300	3m/M6
8000	2m/M5
10000	1Am/M4

Headroom - C dimension	
Standard	892 mm
with HS22 Hook operated limit switch	942 mm

Standard rail gauges are 1400, 1700, 2000, 2400, 2700, 3100, 3400, 3800, and 4200 mm.

H1 and M2 are listed at Min R.

Hoist weight calculated at Min R, with P6 motor, without drum brake.

This document is the absolute property of R&M Materials Handling, Inc. This document must not be copied without the written permission of R&M Materials Handling, Inc. The contents thereof must not be disclosed to a third party nor be used for any unauthorized purpose. Contravention will be prosecuted.

ETTPAL Design	ETTPAL Chd	Appd	Ref Drawing	QD-M-02
2002-09-02 Date	TROLLEY; DOUBLE GIRDER			1:19
SLEODOCV Owner Dept	MEDIUM, 2 ROPE FALLS			Folder
R&M MATERIALS HANDLING INC.	R&M MATERIALS HANDLING, INC. HOIST & CRANE PRODUCTS SPRINGFIELD, OHIO	D006647-A		Issue 6