

NORMAL HEADROOM, 2 PART DOUBLE
Hoist type:
SX6 022...N0

SI-60Hz

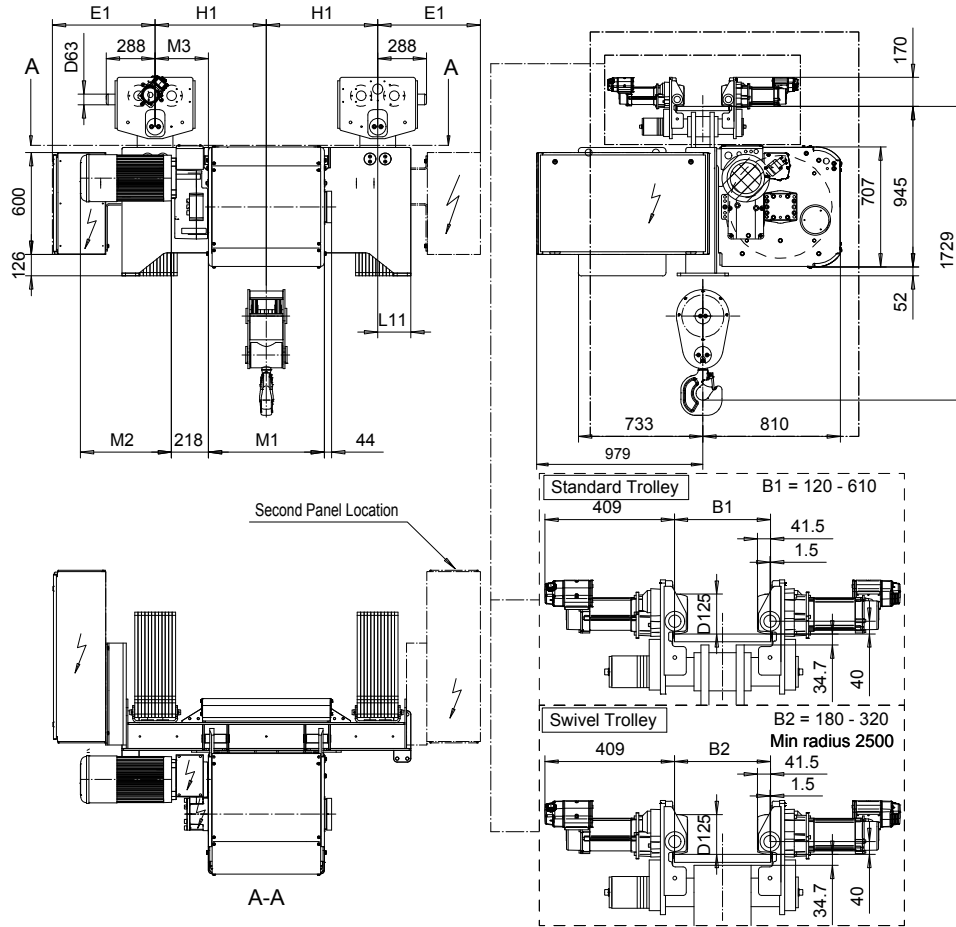

HOL	HOL*	Length	E1	M1	M3	H1	L11	Wgt - Std Ttry	Wgt - Swivel Ttry
(m)	(m)	code	(mm)	(mm)	(mm)	(mm)	(mm)	(kg)	(kg)
15	8.5	E	605	682	314	655	195	2000	2200
21	14.5	F	605	832	239	655	195	2100	2300
28.5	22	G	605	1022	144	655	195	2300	2500
38	31.5	H	605	1272	319	955	195	2500	2800
51.5	45	J	605	1622	144	955	195	2800	3100
63.5	57	K	925	1922	-306	655	520	3000	3300
77	70.5	L	925	2272	-481	655	520	3300	3600
87	80.5	M	900	2522	-306	955	495	3600	4000
98.5	92	N	900	2822	-456	955	495	3800	4300

Note: Hoist weight when B = 205 mm
 HOL* with optional drum brake Weight of drum brake 80 kg

Load	Class
(kg)	Fem/ISO
6300	3m/M6
8000	2m/M5
10000	1Am/M4

Motor	P6	P7	P8	A7	S7	S8	SA
M2 (mm)	536	576	711	536	715	763	803
Weight (kg)	85	105	106	71	81	97	120

This document is the absolute property of R&M Materials Handling, Inc. This document must not be copied without the written permission of R&M Materials Handling, Inc. The contents thereof must not be disclosed to a third party nor be used for any unauthorized purpose. Contravention will be prosecuted.

CSDTLI Design	KHHMKH Chd	Appd	Ref Drawing	QD-N-22
2010-11-30 Date	TROLLEY; NORMAL HEADROOM			1 of 19 Folder
SLEODOCV Owner Dept	2X2 ROPE FALLS			
R&M MATERIALS HANDLING INC.	R&M MATERIALS HANDLING, INC. HOIST & CRANE PRODUCTS SPRINGFIELD, OHIO	D006895-A		Issue 02/2016