

FOOT MOUNT, 6 PART SINGLE

Hoist type:

SX6 061...F0

SI-60Hz

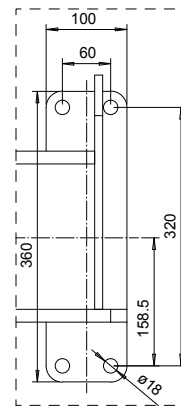
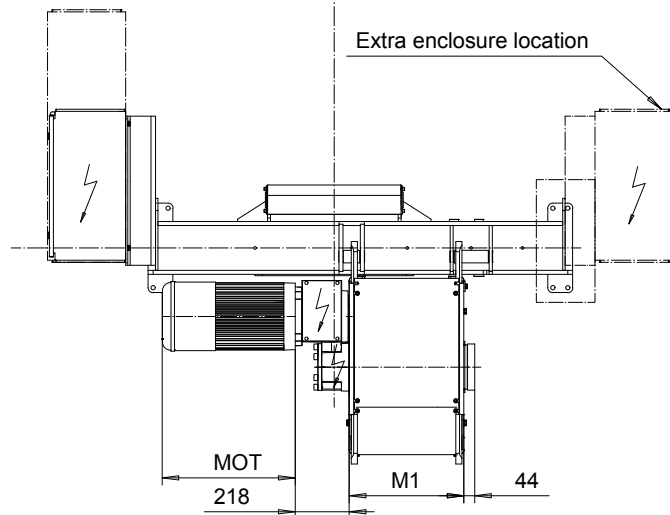
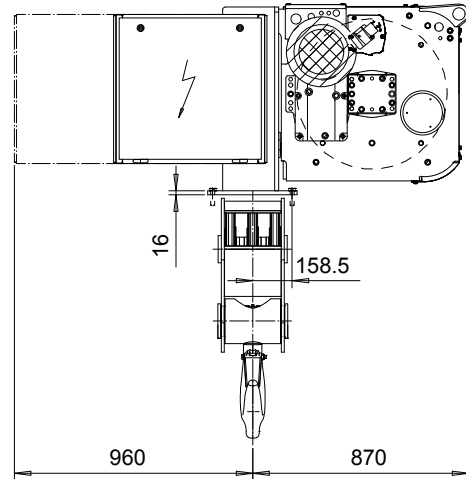
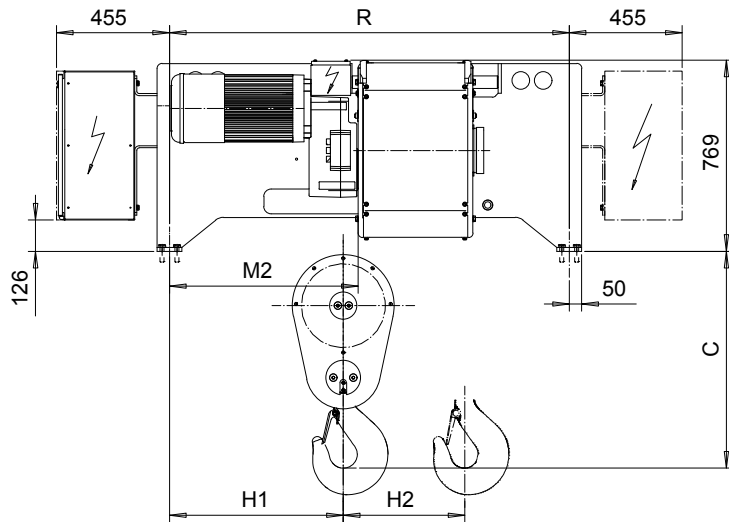

HOL (m)	HOL* (m)	Length code	R (mm)	M1 (mm)	M2 (mm)	H1 (mm)	H2 (mm)	Approx Weight (kg)
5	3	C	1610	462	760	700	46	1300
7	5	D	1610	562	760	700	63	1400
9	7	E	1840	682	590	650	84	1500
12	10	F	1840	832	590	650	107	1500
15.5	13.5	G	2350	1022	670	730	140	1600
20	18	H	2350	1272	670	730	182	1800
26.5	24.5	J	2759	1622	840	690	240	2000
32	30	K	2759	1922	840	690	289	2100

HOL* with optional drum brake Weight of drum brake is 80 kg.

Motor	P6	P7	P8	A7	S7	S8	SA
MOT (mm)	536	576	711	536	715	763	803
Weight (kg)	85	105	106	71	81	97	120

Load (kg)	Class Fem/ISO
20000	3m/M6
25000	2m/M5
30000	1Am/M4

Headroom - C dimension	
Standard	873 mm
with HS22 Hook operated limit switch	923 mm

Hoist weight calculated with P6 motor weight and without drum brake.

This document is the absolute property of R&M Materials Handling, Inc. This document must not be copied without the written permission of R&M Materials Handling, Inc. The contents thereof must not be disclosed to a third party nor be used for any unauthorized purpose. Contravention will be prosecuted.

ETTPAL Design	ETTPAL Chd	Appd	Ref Drawing	QD-F-06
2002-09-02 Date	HOIST; FIXED			1:13
SLEODOCV Owner Dept	6 ROPE FALLS			Folder
R&M MATERIALS HANDLING INC.	R&M MATERIALS HANDLING INC. HOIST & CRANE PRODUCTS SPRINGFIELD, OHIO	D006938-A		Issue 11/2013