

# DOUBLE GIRDER, MEDIUM, 6 PART DOUBLE

Hoist type:  
SX6 062...D0

SI-50Hz

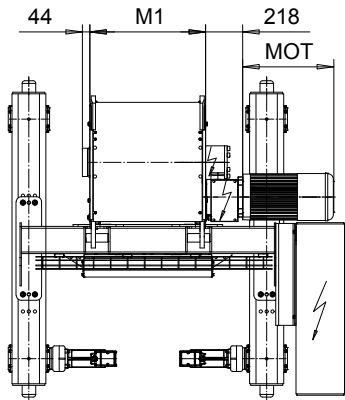
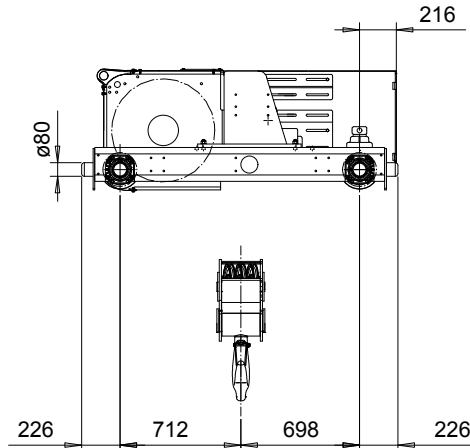
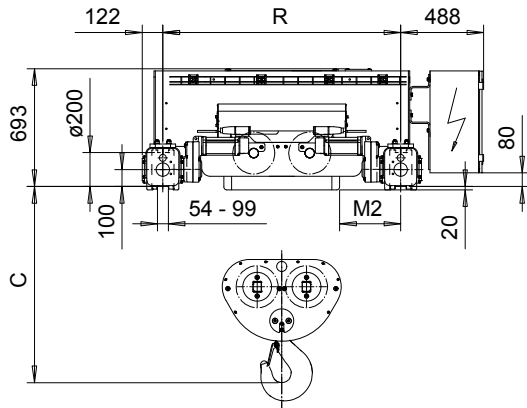

HOL	HOL*	Length	M1	M2	Min R	Max R	Approx Weight
(m)	(m)	code	(mm)	(mm)	(mm)	(mm)	(kg)
5	N.A.	E	682	359	1400	2000	1650
7	5	F	832	434	1700	2400	1730
9.5	7.5	G	1022	338	1700	2700	1800
12.5	10.5	H	1272	364	2000	3100	1920
17	15	J	1622	389	2400	3400	2100
21	19	K	1922	389	2700	3400	2280
25.5	23.5	L	2272	414	3100	3400	2490
28.5	26.5	M	2522	439	3400	3800	2660
32.5	30.5	N	2822	489	3800	4200	2870

HOL\* with optional drum brake Weight of drum brake is 80 kg.

Motor	P6	P7	P8	A7	S7	S8	SA
MOT (mm)	536	576	711	536	715	763	803
Weight (kg)	85	105	106	71	81	97	120

Load	Class
(kg)	Fem/ISO
20000	3m/M6
25000	2m/M5
30000	1Am/M4

Headroom - C dimension	
Standard	1154 mm
with HS22 Hook operated limit switch	1204 mm

Standard rail gauges are 1400, 1700, 2000, 2400, 2700, 3100, 3400, 3800, and 4200 mm.

M2 is listed at Min R.

Hoist weight calculated at Min R, with P6 motor, without drum brake.

This document is the absolute property of R&M Materials Handling, Inc. This document must not be copied without the written permission of R&M Materials Handling, Inc. The contents thereof must not be disclosed to a third party nor be used for any unauthorized purpose. Contravention will be prosecuted.

ETTPAL Design	ETTPAL Chd	Appd	Ref Drawing	QD-M-26
2002-09-02 Date	TROLLEY; DOUBLE GIRDER			1:19
SLEODOCV Owner Dept	MEDIUM, 2x6 ROPE FALLS			Folder
R&M MATERIALS HANDLING INC.	R&M MATERIALS HANDLING, INC HOIST & CRANE PRODUCTS SPRINGFIELD, OHIO	D006653-A		Issue 4