

NORMAL HEADROOM, 6 PART DOUBLE
Hoist type:
SX6 062...N0

SI-60Hz

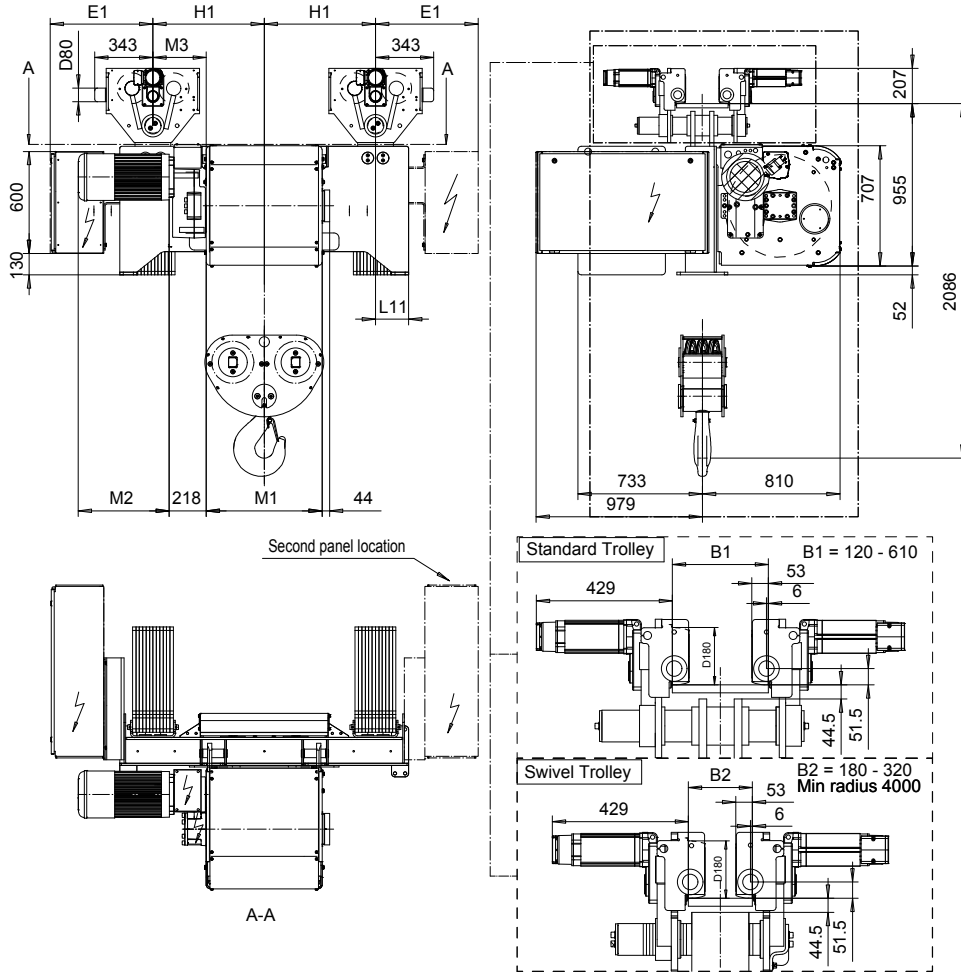

HOL	HOL*	Length	E1	M1	M3	H1	L11	Wgt - Std Ttry	Wgt - Swivel Ttry
(m)	(m)	code	(mm)	(mm)	(mm)	(mm)	(mm)	(kg)	(kg)
5	N.A.	E	605	682	314	655	195	2400	2600
7	5	F	605	832	239	655	195	2500	2700
9.5	7.5	G	605	1022	144	655	195	2700	2900
12.5	10.5	H	605	1272	319	955	195	2900	3200
17	15	J	605	1622	144	955	195	3200	3500
21	19	K	925	1922	-306	655	520	3400	3700
25.5	23.5	L	925	2272	-481	655	520	3700	4000
28.5	26.5	M	900	2522	-306	955	495	4000	4400
32.5	30.5	N	900	2822	-456	955	495	4200	4700

Note: Hoist weight when B = 205 mm
 HOL* with optional drum brake Weight of drum brake 80 kg

Load	Class
(kg)	Fem/ISO
20000	3m/M6
25000	2m/M5
30000	1Am/M4

Motor	P6	P7	P8	A7	S7	S8	SA
M2 (mm)	536	576	711	536	715	763	803
Weight (kg)	85	105	106	71	81	97	120

This document is the absolute property of R&M Materials Handling, Inc. This document must not be copied without the written permission of R&M Materials Handling, Inc. The contents thereof must not be disclosed to a third party nor be used for any unauthorized purpose. Contravention will be prosecuted.

CSDTLI Design	KHHMKH Chd	Appd	Ref Drawing	QD-N-26
20103-11-30 Date	TROLLEY; NORMAL HEADROOM			1 of 19 Folder
SLEODOCV Owner Dept	2x6 ROPE FALLS			
R&M MATERIALS HANDLING INC.	R&M MATERIALS HANDLING, INC. HOIST & CRANE PRODUCTS SPRINGFIELD, OHIO	D006897-A		Issue 2/2016