

NORMAL HEADROOM, 2 PART SINGLE

SI-60Hz

Hoist type:
SX6 021...N0

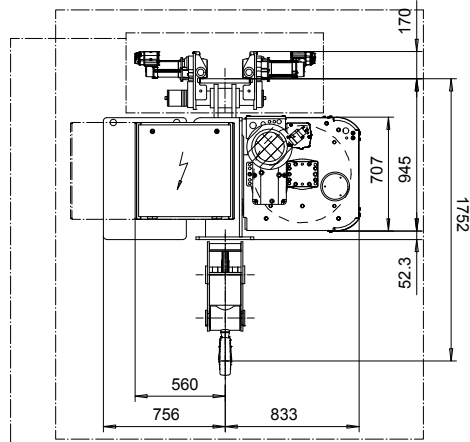
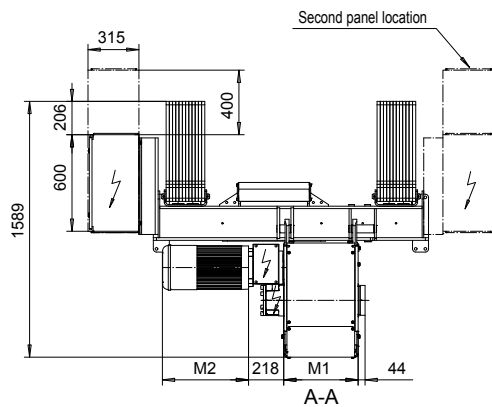
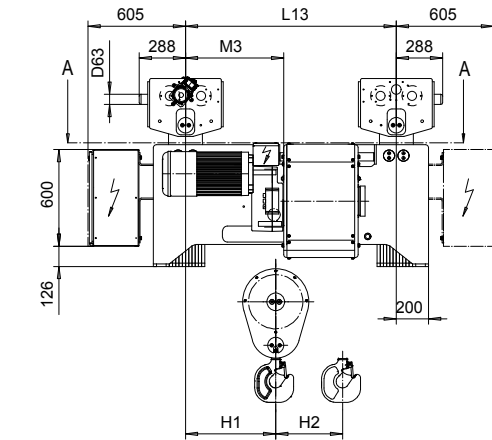

Standard Trolley B1 = 120 - 610

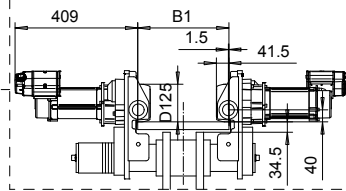

Swivel Trolley B2 = 180 - 320

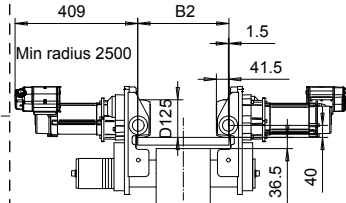

Motor	P6,T6,T7,T8,T9	P7,TA	P8
M2 (mm)	536	576	711

HOL (m)	Length code	M1 (mm)	M3 (mm)	L13 (mm)	H1 (mm)	H2 (mm)	Wgt - Std Ttry (kg)	Wgt - Swivel Ttry (kg)
15.5	C	462	610	1310	561	139	2000	2200
21	D	562	610	1310	561	188	2000	2300
28	E	682	560	1540	511	251	2200	2400
36	F	832	560	1540	511	322	2300	2500
47	G	1022	640	2050	591	421	2500	2700
61	H	1272	640	2050	591	546	2700	2900
80.5	J	1622	600	1910	551	721	3100	3400
97	K	1922	600	1910	551	868	3300	3600

Note: Weight when B = 300mm

Load (kg)	Class Fem/ISO	Hoisting motor					
		Hoisting speed (m/min): Gear code					
		9.5/1.6: E	12/2: F	15/2.5: G	19: H	24: J	
6300	3m/M6	P6,T6	P6,T6	P7,T7	T8	T9	
8000	2m/M5	P6,T6	P6,T6	P7,T7	T8	T9	
10000	1Am/M4	P6,T6	P7,T7	P8,T8	T9	TA	

Hoist Panel Dimensions WxD (mm) + Configuration for Monorail Hoists				
Trolley control type	2-spd or CMXC	CM Select 002	CM Select 003-004	CM Select 005-007
Panel size + 2nd panel size - 380-500V	1000 x 600	1000 x 600	1000 x 600	1000 x 600 + 1000 x 600
Panel size + 2nd panel size - Other Voltages	1000 x 600	1000 x 600	1000 x 600 + 600 x 400	1000 x 600 + 1000 x 600

ETTVPH Design 2010-11-30 Date	ETTPAL Chief SLEQDOCV Designer Dept.	App'd	Ref Drawing	QD-N-02
R&M MATERIALS HANDLING, INC.		TROLLEY; NORMAL HEADROOM		
R&M MATERIALS HANDLING, INC. HOIST & CRANE PRODUCTS SPRINGFIELD, OHIO		2 ROPE FALLS		
D006985-A		11/2010		

This document is the absolute property of R&M Materials Handling, Inc. This document must not be copied without the written permission of R&M Materials Handling, Inc. The contents thereof must not be disclosed to a third party nor be used for any unauthorized purpose. Contravention will be prosecuted.