

Hoist type:
SXL17...R3400

SI units

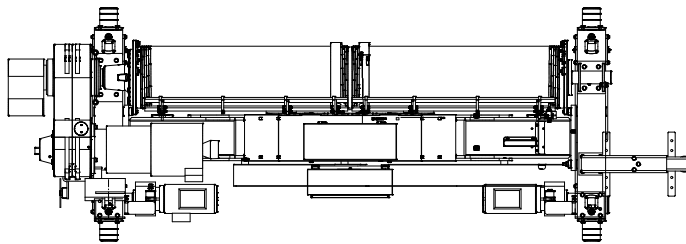
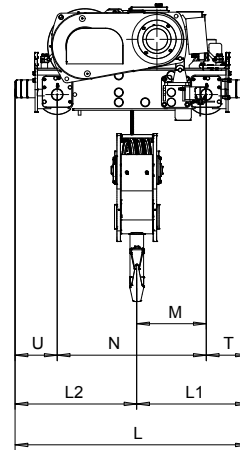
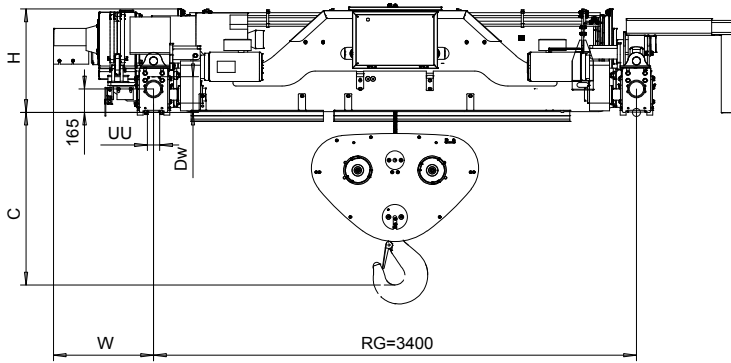

Hoisting trolley type	Duties 03...06	Hoisting trolley dimensions (mm)									Rail wheel (mm)		C (mm)		Weight (Kg)	
		H	M	N	L	L1	L2	T	U	W	Dw	UU*	RG34	RG34		
SXL17022	X	729	579	1050	1642	875	767	296	296	705	250	86	1165	4010		
SXL17032	X	729	529	1050	1642	825	817	296	296	705	250	86	1045	4130		
SXL17042	X	729	532	1050	1642	828	814	296	296	705	250	86	1045	4140		
SXL17052	X	729	513	1050	1642	809	833	296	296	705	250	86	1130	4390		
SXL17062	X	729	483	1050	1642	779	863	296	296	705	250	86	1130	4400		
SXL17082	X	729	452	1050	1642	748	894	296	296	705	250	86	1255	4830		

Weight of the service platform is not included into trolley weight.* UU based on 80 mm rail.

DES/WHO					Chd	Appd	Ref Drawing	
2011-06-17					TROLLEY; DOUBLE GIRDER			
Date					SXL17			
Owner Dept					SXL17-R3400			
R&M MATERIALS HANDLING INC.					DA002667			
R&M MATERIALS HANDLING, INC. HOIST & CRANE PRODUCTS SPRINGFIELD, OHIO								
Rev	Explanation	Date	Revised by	Checked by				1:25
This document is the absolute property of R&M Materials Handling, Inc. This document must not be copied without the written permission of R&M Materials Handling, Inc. The contents thereof must not be disclosed to a third party nor be used for any unauthorized purpose. Contravention will be prosecuted.								Folder
								Issue
								3