

Hoist type:
SXL17...R3400

US units

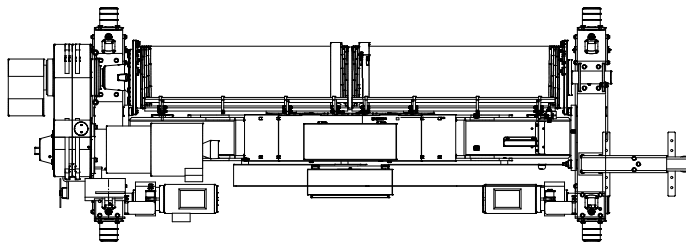
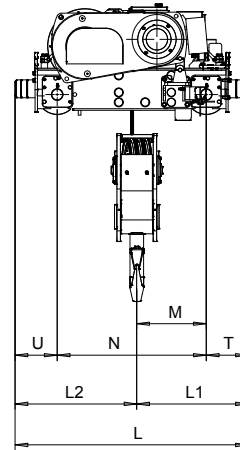
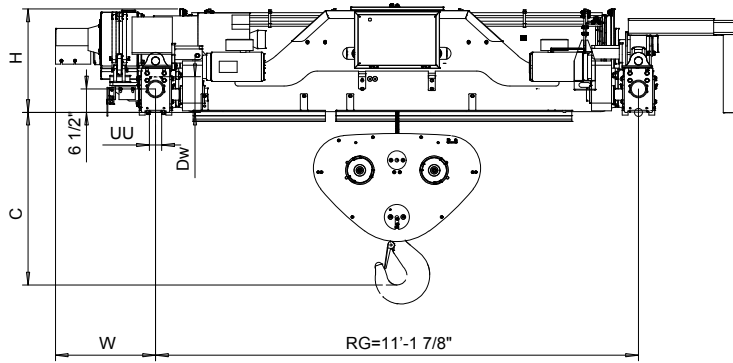

Hoisting trolley type	Duties 03...06	Hoisting trolley dimensions (inch)									Rail wheel (inch)		C (inch)		Weight (lb)	
		H	M	N	L	L1	L2	T	U	W	Dw	UU*	RG34	RG34		
SXL17022	X	28 3/4"	22 13/16"	41 3/8"	64 11/16"	34 7/16"	31 1/4"	11 5/8"	11 5/8"	27 3/4"	9.84"	3 3/4"	45 7/8"	8841		
SXL17032	X	28 3/4"	20 7/8"	41 3/8"	64 11/16"	32 1/2"	32 3/16"	11 5/8"	11 5/8"	27 3/4"	9.84"	3 3/4"	41 1/4"	9105		
SXL17042	X	28 3/4"	20 15/16"	41 3/8"	64 11/16"	32 5/8"	32 1/16"	11 5/8"	11 5/8"	27 3/4"	9.84"	3 3/4"	41 1/4"	9127		
SXL17052	X	28 3/4"	20 1/4"	41 3/8"	64 11/16"	31 7/8"	32 13/16"	11 5/8"	11 5/8"	27 3/4"	9.84"	3 3/4"	44 1/2"	9678		
SXL17062	X	28 3/4"	19"	41 3/8"	64 11/16"	30 11/16"	34"	11 5/8"	11 5/8"	27 3/4"	9.84"	3 3/4"	44 1/2"	9700		
SXL17082	X	28 3/4"	17 13/16"	41 3/8"	64 11/16"	26 7/16"	35 1/4"	11 5/8"	11 5/8"	27 3/4"	9.84"	3 3/4"	49 1/2"	10648		

Weight of the service platform is not included into trolley weight. * UU based on 3 1/2" rail.

This document is the absolute property of R&M Materials Handling, Inc. This document must not be copied without the written permission of R&M Materials Handling, Inc. The contents thereof must not be disclosed to a third party nor be used for any unauthorized purpose. Contravention will be prosecuted.

DESHPYO Design	Chd	Appd	Ref Drawing
2011-06-17 Date	TROLLEY; DOUBLE GIRDER		
Owner Dept	SXL17		
R&M MATERIALS HANDLING INC.	R&M MATERIALS HANDLING, INC. HOIST & CRANE PRODUCTS SPRINGFIELD, OHIO	SXL17-R3400	
DA002667		1 of 25	Folder
		Issue	3