

Hoist type:
SXL20...R3400

SI units

6-WHEEL TROLLEY

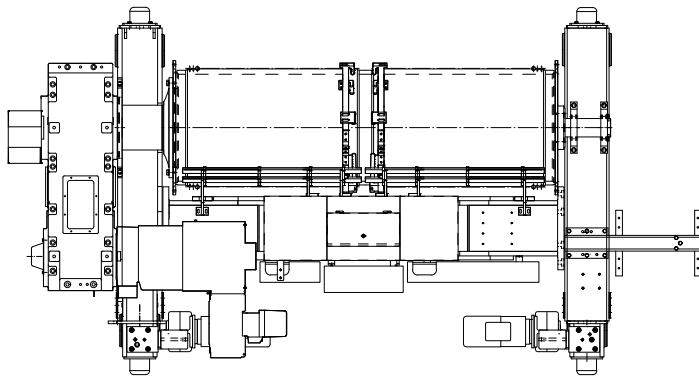
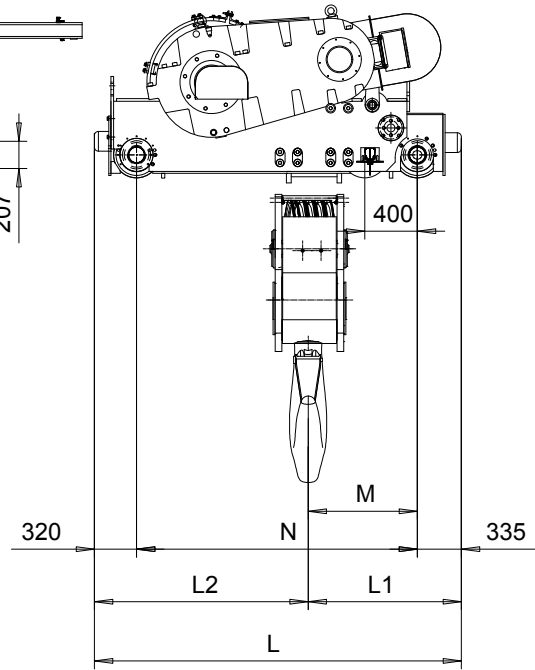
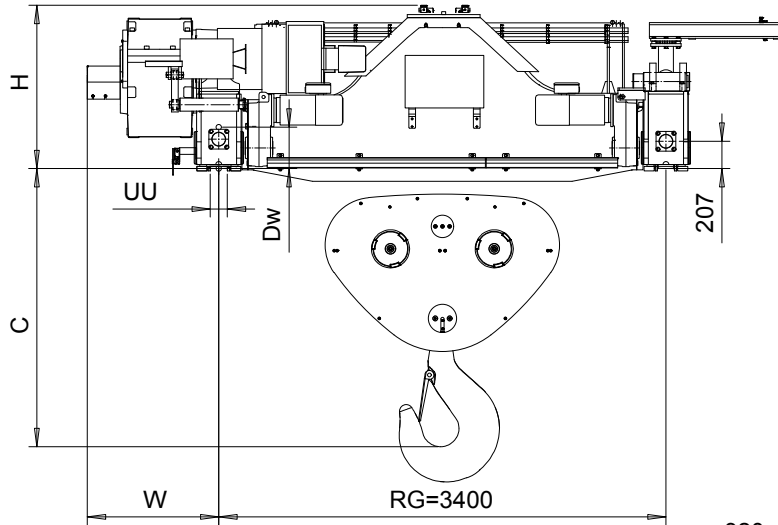

Trolley	Duty 03...06	Hoisting trolley dimensions (mm)							Rail wheel (mm)		C (mm)	Weight (Kg)
		H	M	N	L	L1	L2	W	Dw	UU*	(34)	(34)
SXL20022	X	1250	920	2135	2790	1255	1535	1000	315	106	1935	14890
SXL20032	X	1250	920	2135	2790	1255	1535	1000	315	106	2145	15190
SXL20042	X	1250	890	2135	2790	1225	1565	1000	315	106	1890	15700
SXL20052	X	1250	880	2135	2790	1215	1575	1000	315	106	2245	16180
SXL20062	X	1250	860	2135	2790	1195	1595	1000	315	126	2005	16710
SXL20082	X	1250	830	2135	2790	1165	1625	1000	315	126	2115	17480

Weight of the service platform is not included into the trolley weight. *UU based on 100 mm or 120 mm rail.

Rev Explanation Date Revised by Checked by
This document is the absolute property of R&M Materials Handling, Inc. This document must not be copied without the written permission of R&M Materials Handling, Inc. The contents thereof must not be disclosed to a third party nor be used for any unauthorized purpose. Contravention will be prosecuted.

DESHPYO Design 2011-06-17 Date	Chd	Appd	Ref Drawing	1:27 Folder
Owner Dept R&M MATERIALS HANDLING INC.	TROLLEY; DOUBLE GIRDER SXL20			
R&M MATERIALS HANDLING, INC. HOIST & CRANE PRODUCTS SPRINGFIELD, OHIO	SXL20-R3400			Issue 1
	DA003421			