

# Normal Headroom - Swivel Trolley for Curved Track, 4 PART SINGLE

## Hoist type:

US-60Hz

SXR5 041..U

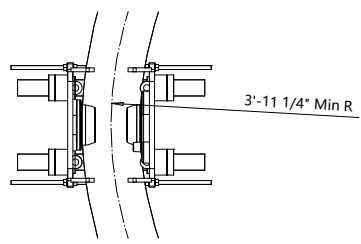
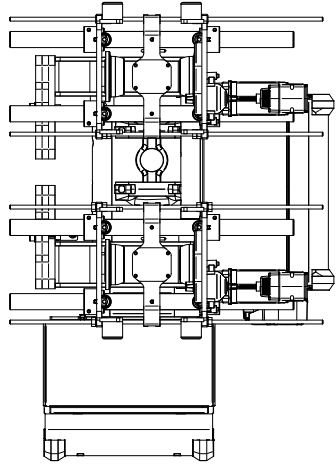
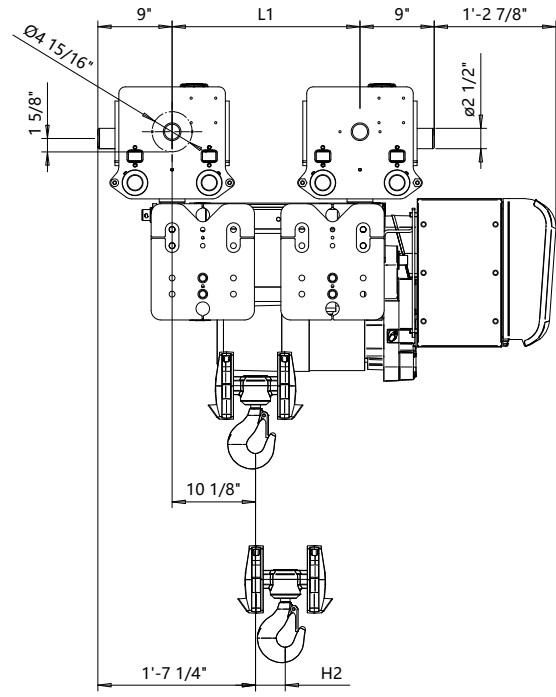
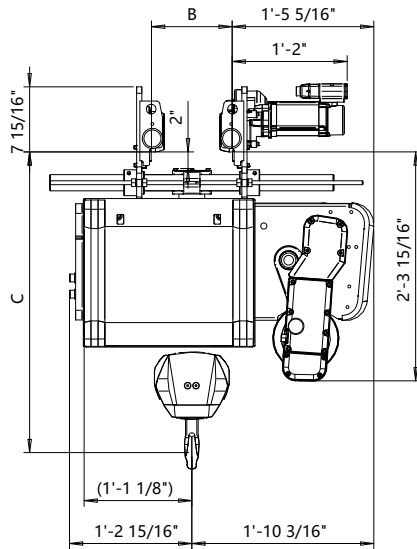

Flange Width	Headroom C-Dimension				
	Case 1	Case 2	Case 3	Case 4	Case 5
B-dimension	[inch]	[inch]	[inch]	[inch]	[inch]
4" - 17 3/4"	29 11/16"	36 3/4"	39 1/8"	32 1/2"	36 1/4"
Case 1: Steel rope without HS22 limit switch					
Case 2: Steel rope with HS22 limit switch					
Case 3: Steel rope with HS22 L.S. & Rope angle sensor					
Case 4: Synthetic rope with HS22 limit switch					
Case 5: Synthetic rope with HS22 L.S. & Rope angle sensor					
HS22 limit switch mandatory with synthetic rope					

Load (ton)	Class ASME
3	H4+
4	H4+
5	H4
6	H3

HOL	Length	H2	L1	Estimated Weight
(ft-in)	code	(inch)	(inch)	(lb)
21'-4"	B	3 5/8"	1'-10 15/16"	1092
29'-6"	C	5 1/2"	2'-5"	1160
39'-4"	D	7 1/4"	3'-0 1/8"	1180

Design	Chd	Appd	Ref Drawing	R5-U-04
Date	NORMAL HEADROOM HOIST - SWIVEL TROLLEY			
SLEOMECE Owner/Dept	FOR CURVED TRACK			
	4 PART SINGLE			
	R5041_U			

This document is the absolute property of R&M Materials Handling, Inc. This document must not be copied without the written permission of R&M Materials Handling, Inc. The contents thereof must not be disclosed to a third party nor be used for any unauthorized purpose. Contravention will be prosecuted.

