

R&M Materials Handling, Inc.
 4501 Gateway Boulevard
 Springfield, Ohio 45502
 ☎ : (937) 328-5100
 FAX: (937) 325-5319

6.7 RT50

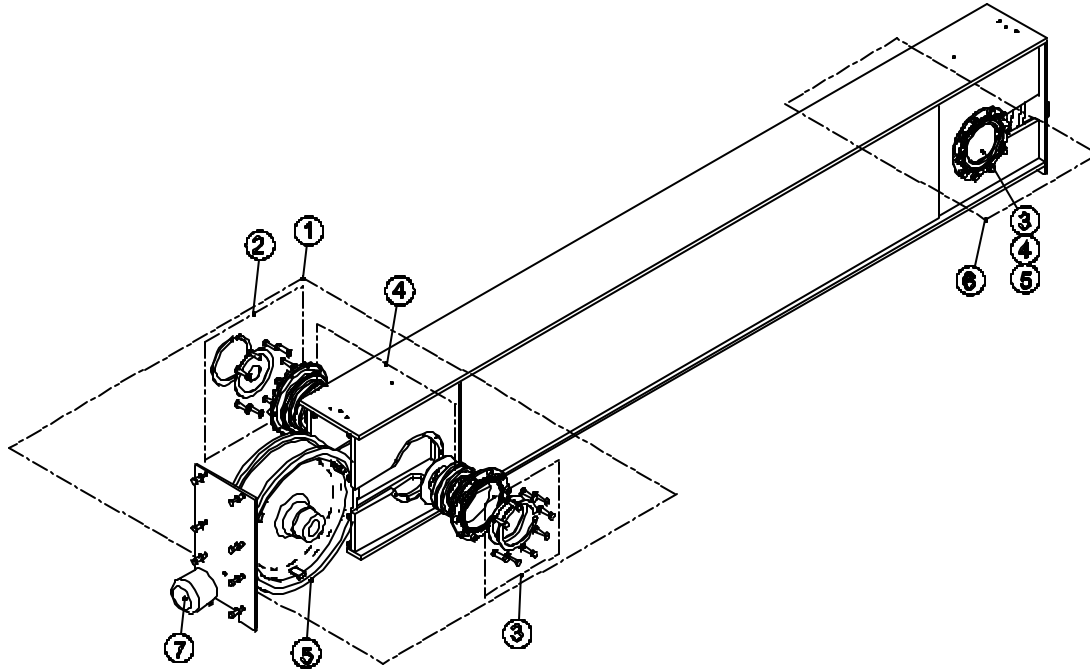

005747_1

Pos.	Item Code	From	To	Description	Pcs
1	3000001780			WHEEL SET; DRIVE 1: Wheel groove = 55	1
1	3000001781			WHEEL SET; DRIVE 1: Wheel groove = 60	1
1	3000001782			WHEEL SET; DRIVE 1: Wheel groove = 65	1
1	3000001783			WHEEL SET; DRIVE 1: Wheel groove = 70	1
1	3000001784			WHEEL SET; DRIVE 1: Wheel groove = 75	1
1	3000001785			WHEEL SET; DRIVE 1: Wheel groove = 80	1
1	3000001786			WHEEL SET; DRIVE 1: Wheel groove = 85	1
1	3000001787			WHEEL SET; DRIVE 1: Wheel groove = 90	1
1	3000001788			WHEEL SET; DRIVE 1: Wheel groove = 95	1
1	3000001789			WHEEL SET; DRIVE 1: Wheel groove = 100	1
2	3000001803			HARDWARE SET	1
3	3000001800			HARDWARE SET	3
4	3000001805			BEARING SET	2
5	-			WHEEL 1: Wheel groove = 85	



R&M Materials Handling, Inc.
 4501 Gateway Boulevard
 Springfield, Ohio 45502
 ☎ : (937) 328-5100
 FAX: (937) 325-5319

5	-	WHEEL 1: Wheel groove = 80	
5	-	WHEEL 1: Wheel groove = 55	
5	-	WHEEL 1: Wheel groove = 60	
5	-	WHEEL 1: Wheel groove = 65	
5	-	WHEEL 1: Wheel groove = 70	
5	-	WHEEL 1: Wheel groove = 75	
5	-	WHEEL 1: Wheel groove = 90	
5	-	WHEEL 1: Wheel groove = 95	
5	-	WHEEL 1: Wheel groove = 100	
6	3000001790	WHEEL SET; IDLER 1: Wheel groove = 55	1
6	3000001791	WHEEL SET; IDLER 1: Wheel groove = 60	1
6	3000001792	WHEEL SET; IDLER 1: Wheel groove = 65	1
6	3000001793	WHEEL SET; IDLER 1: Wheel groove = 70	1
6	3000001794	WHEEL SET; IDLER 1: Wheel groove = 75	1
6	3000001795	WHEEL SET; IDLER 1: Wheel groove = 80	1
6	3000001796	WHEEL SET; IDLER 1: Wheel groove = 85	1
6	3000001797	WHEEL SET; IDLER 1: Wheel groove = 90	1
6	3000001798	WHEEL SET; IDLER 1: Wheel groove = 95	1
6	3000001799	WHEEL SET; IDLER 1: Wheel groove = 100	1
7	3000001140	BUFFER 1: Buffer type = B	2
7	3000001837	BUFFER 1: Buffer type = C	2
7	3000001838	BUFFER 1: Buffer type = D	2
7	3000001830	BUFFER 1: Buffer type = E	2
7	3000001831	BUFFER 1: Buffer type = M	2
7	3000001832	BUFFER 1: Buffer type = F	2
7	3000001833	BUFFER 1: Buffer type = H	2



R&M Materials Handling, Inc.
4501 Gateway Boulevard
Springfield, Ohio 45502

☎ : (937) 328-5100
FAX: (937) 325-5319

7	3000001834	BUFFER 1: Buffer type = P	2
7	3000001835	BUFFER 1: Buffer type = I	2
7	3000001836	BUFFER 1: Buffer type = S	2