

GES4 - F06 BRIDGE DRIVE

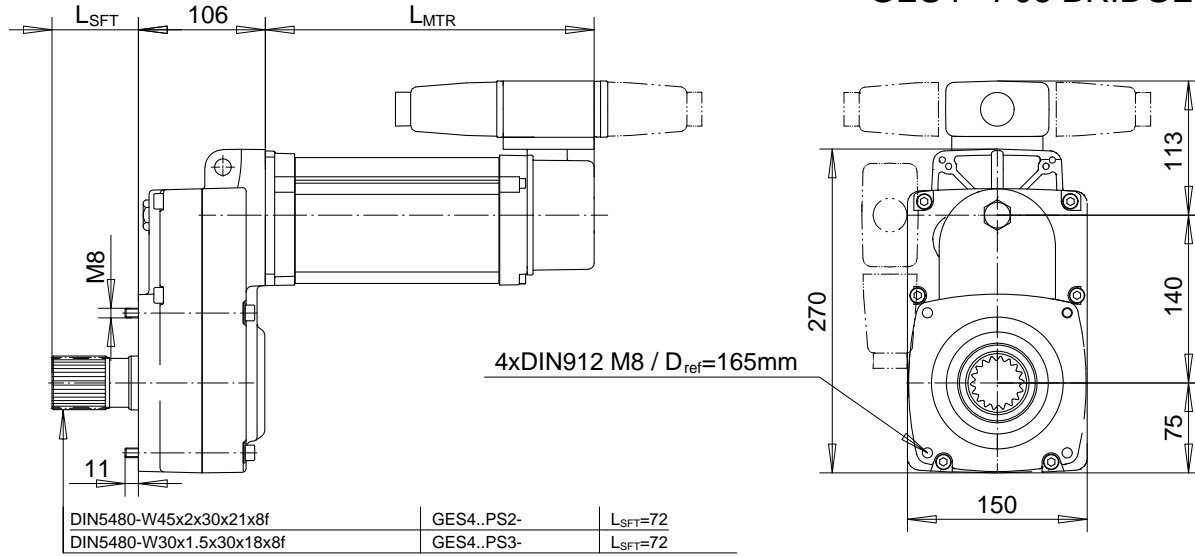

MACHINERY TYPE	RATIO	T 2max (***)	3000 rpm MOTOR [m/min] (**)			3600 rpm MOTOR [fpm] (**)		
			Dw=320	Dw=250	Dw=200	Dw=320	Dw=250	Dw=200
GES4B0PS.BOF06	107.8	680 Nm	25	20	16	100	80	63
GES490PS.BOF06	89.03	650 Nm	32	25	20	125	100	80
GES472PS.BOF06	72.80	570 Nm	40	32	25	160	125	100
GES463PS.BOF06	60.13	550 Nm	50	40	32	200	160	125

SUITABLE MF06 INVERTER MOTORS					
MOTOR TYPE	L mtr	P n	U/f	n s	T n
MF06MA200 (****)	235 mm	0.30 kW	3~400V/100 Hz	3000 rpm	1.0 Nm
MF06MA200 (****)	235 mm	0.37 kW	3~460V/120 Hz	3600 rpm	1.0 Nm
MF06MA100 (****)	235 mm	0.45 kW	3~400V/ 80 Hz	4800 rpm	0.9 Nm
MF06LA200 (****)	275 mm	0.45 kW	3~400V/100 Hz	3000 rpm	1.5 Nm
MF06LA200 (****)	275 mm	0.55 kW	3~460V/120 Hz	3600 rpm	1.5 Nm
MF06LA200 (****)	275 mm	0.65 kW	3~400V/100 Hz	3000 rpm	2.6 Nm
MF06LA200 (****)	275 mm	0.75 kW	3~460V/120 Hz	3600 rpm	2.6 Nm
MF06LA100 (****)	275 mm	0.65 kW	3~400V/ 80 Hz	4800 rpm	1.4 Nm
MF06LB200	275 mm	1.1 kW	3~400V/100 Hz	3000 rpm	3.8 Nm
MF06LB200	275 mm	1.1 kW	3~460V/120 Hz	3600 rpm	3.1 Nm
MF06LB100	275 mm	1.1 kW	3~400V/ 80 Hz	4800 rpm	2.3 Nm

OPTIONAL MF06 POLE CHANGE MOTORS NOTE: 2-PHASE BRAKING REQUIRED					
MOTOR TYPE	L mtr	P n	U/f	n s	T n
MF06MA104 (****)	235 mm	0.30/0.05 kW	3~400V/50 Hz	3000/750 rpm	1.0 Nm
MF06MA104 (****)	235 mm	0.37/0.07 kW	3~460V/60 Hz	3600/900 rpm	1.0 Nm
MF06LA104 (****)	275 mm	0.45/0.10 kW	3~400V/50 Hz	3000/750 rpm	1.6 Nm
MF06LA104 (****)	275 mm	0.55/0.12 kW	3~460V/60 Hz	3600/900 rpm	1.6 Nm

(^c) SPEED IS CALCULATED WITH AN AVERAGE SLIP. ACTUAL SPEED DEPENDS ON LOAD, MOTOR AND INVERTER.
(^d) TRAVELLING SPEED WITH OTHER MOTOR SPEED THAN SHOWN ON TABLE CAN BE DERIVED FROM THE MOTOR SPEED DIFFERENCE, EG. WITH 4800rpm MOTORS THE MAXIMUM SPEED IS THE TABLE SPEED MULTIPLIED BY 1.6 (=4800/3000).
(^e) MAXIMUM SECONDARY TORQUE WITH THE S2 SHAFT END (W45x2). WITH S3 SHAFT END (W30x1.5) THE TORQUE SHALL NOT EXCEED 490Nm.
(^f) ONLY FOR RATIOS 90 AND B0.

COMPONENTS - BRIDGE DRIVE

Dimensions are for reference in estimating only. Use of various modifications may affect overall dimensional outline. Where dimensions are critical, request certified drawings for construction. All dimensions are in millimeters unless otherwise noted.	Wt. kg (lb)	Chd	Appd	p_QX.GES4DP01A1 File	
		2002-09-23 Date	QX.GES4DP01A1		
		R&M	R&M Materials Handling Inc.		
		MATERIALS HANDLING	4501 Gateway Blvd, Springfield		
		INC.	GES4-F06 DRIVE	Issue 3/2006	