

Fixed to inverter travel trolley TMU2 - 1 Fall (perpendicular version)

Max. 250 Kg

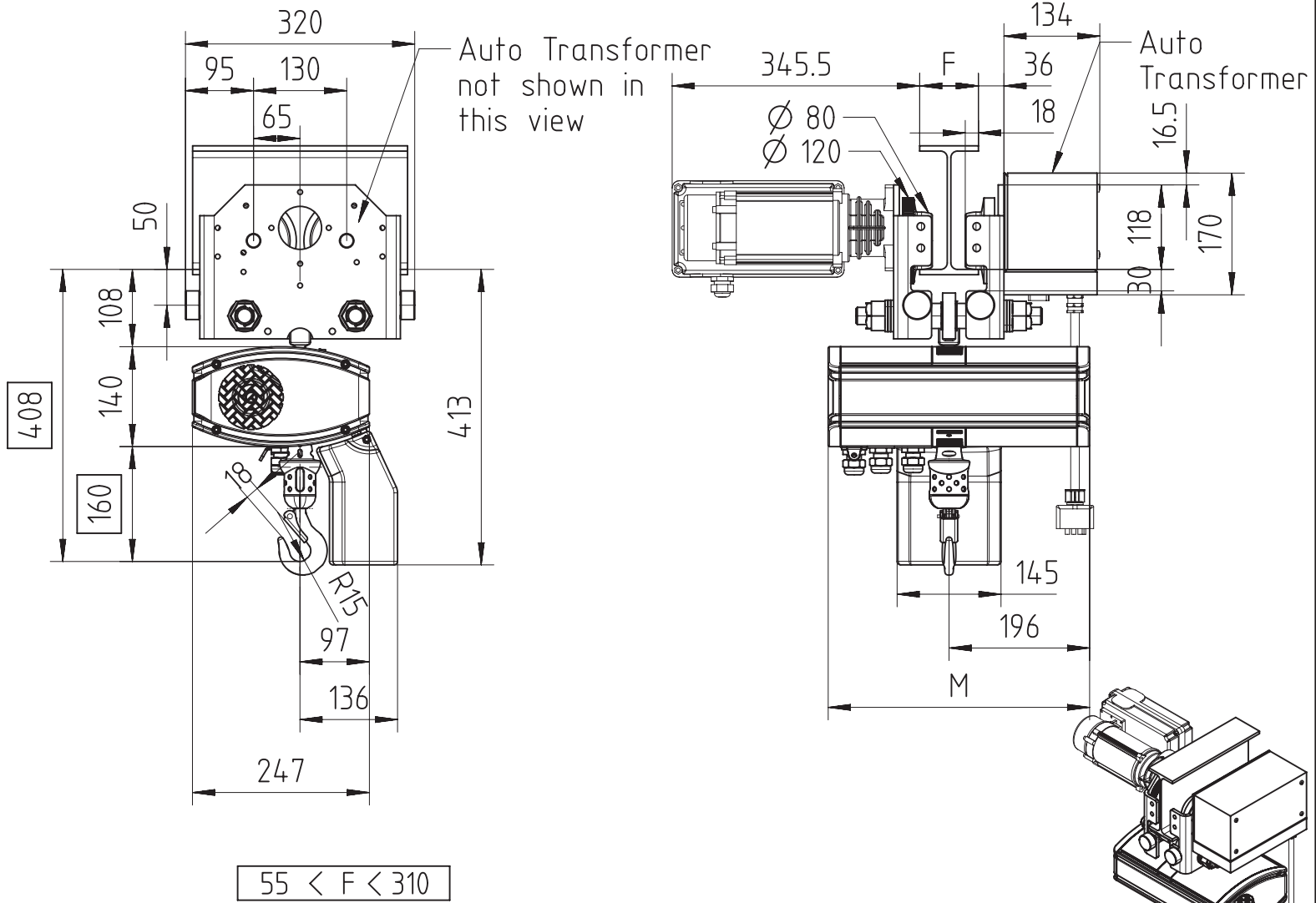

Note: For hoisting speed 16 m/min and higher, add 63 mm to dimension **408** and **160**.

Chain Size	Max load Kg	Chain bag capacity m	Weight per meter Kg/m	Estimated unit weight w/o chain Kg		
				LK	GLS	DB
4x11	250	8	0.37	47.7	49.5	49.8
Dimension M in mm				365	454	417

GLS: Gear Limit Switch  
DB : Double Brake