

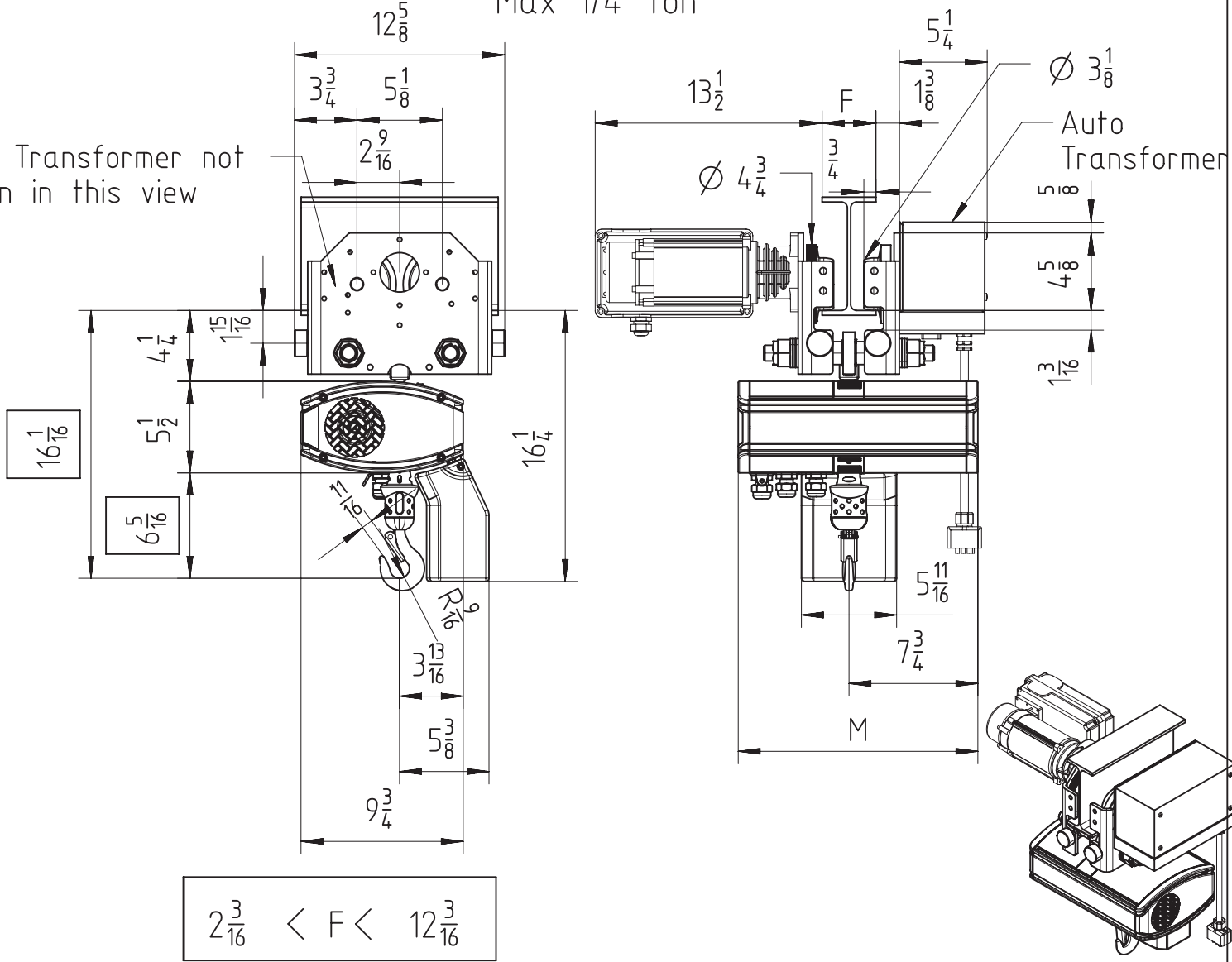

Fixed to inveter travel trolley TMU2 - 1 Fall (perpendicular version)

Max 1/4 Ton

Auto Transformer not shown in this view



Note: For hoisting speed 63 ft/min and higher, add 2 1/2 inches to dimension $16 \frac{1}{16}$ and $6 \frac{5}{16}$

Chain Size	Max load Ton	Chain bag capacity ft	Chain weight per foot lb/ft	Estimated Unit weight w/o chain lb		
				LK	GLS	DB
4x11	1/4	26.2	0.25	105.2	109.1	109.8
Dimension M in inches				14 3/8	17 7/8	16 7/16

GLS: Gear Limit Switch
DB : Double Brake