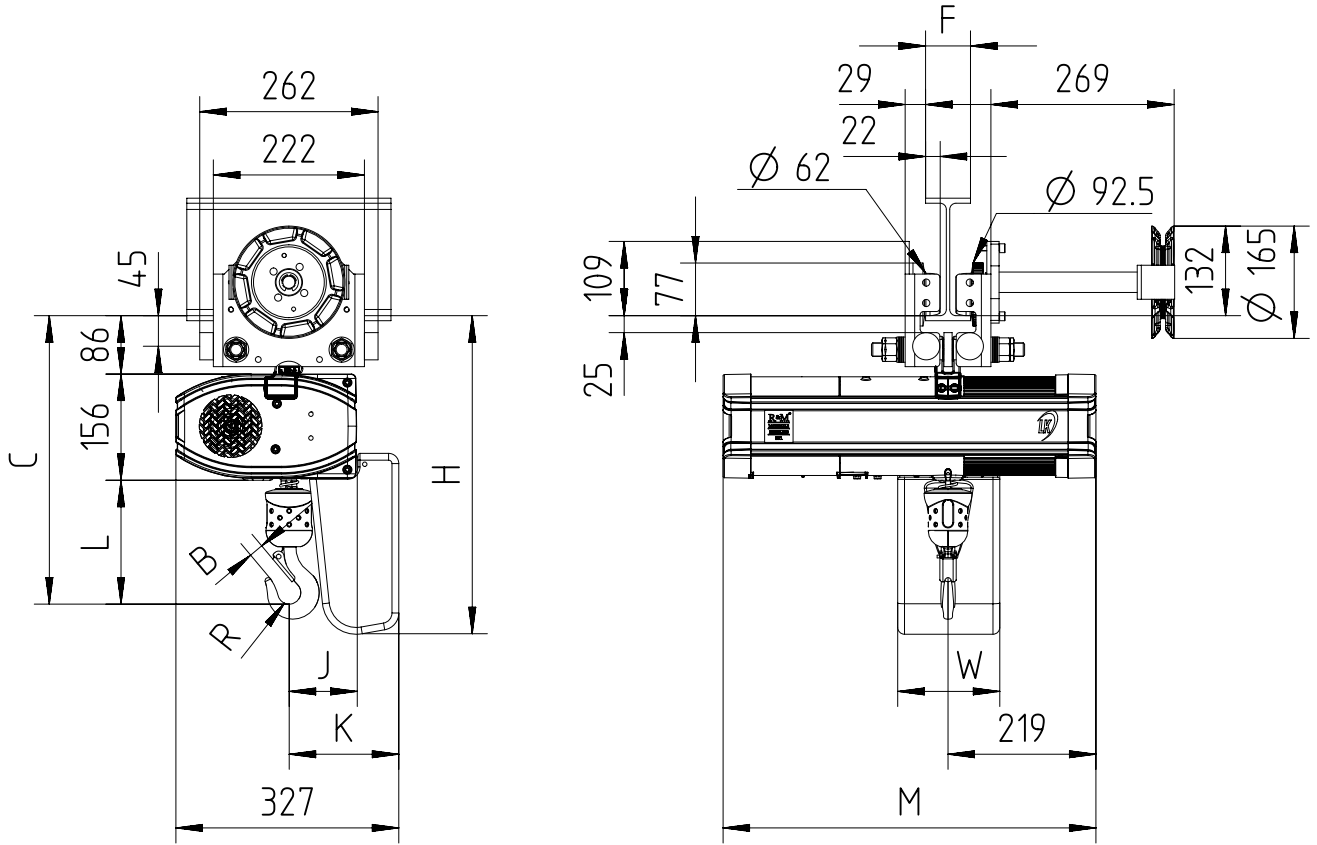

Fixed to Hand chain trolley C1 max 1000 kg (perpendicular version)

 $55 < F < 310$

 Note: Mini. radius of curve for C1 trolley is 2m.
 Note: In case of 2-fall hoist, hook suspension is rotated by 180°.

Chain Size (mm)	Max load (kg)	Falls	Chain bag capacity (m)	Dimensions (mm)								W	M	Weight of chain (kg/m)	Estimated weight of hoist incl. trolley w/o chain (kg)
				B	C	L	R	J	K	H					
5X14	630	1	6	21	424	182	17	100	161	468	150	548	0.57	53	
			16							533					
			25							653					
	1000	2	6 (*)	27	485	243	21	123	184	468					
			16 (*)							533					
			25 (*)							653					

(*) In case of 2-fall hoist, available lifting height is half of the chain bag maximum capacity