

Fixed to Hand chain trolley C1 max 0.5 TON (perpendicular version)

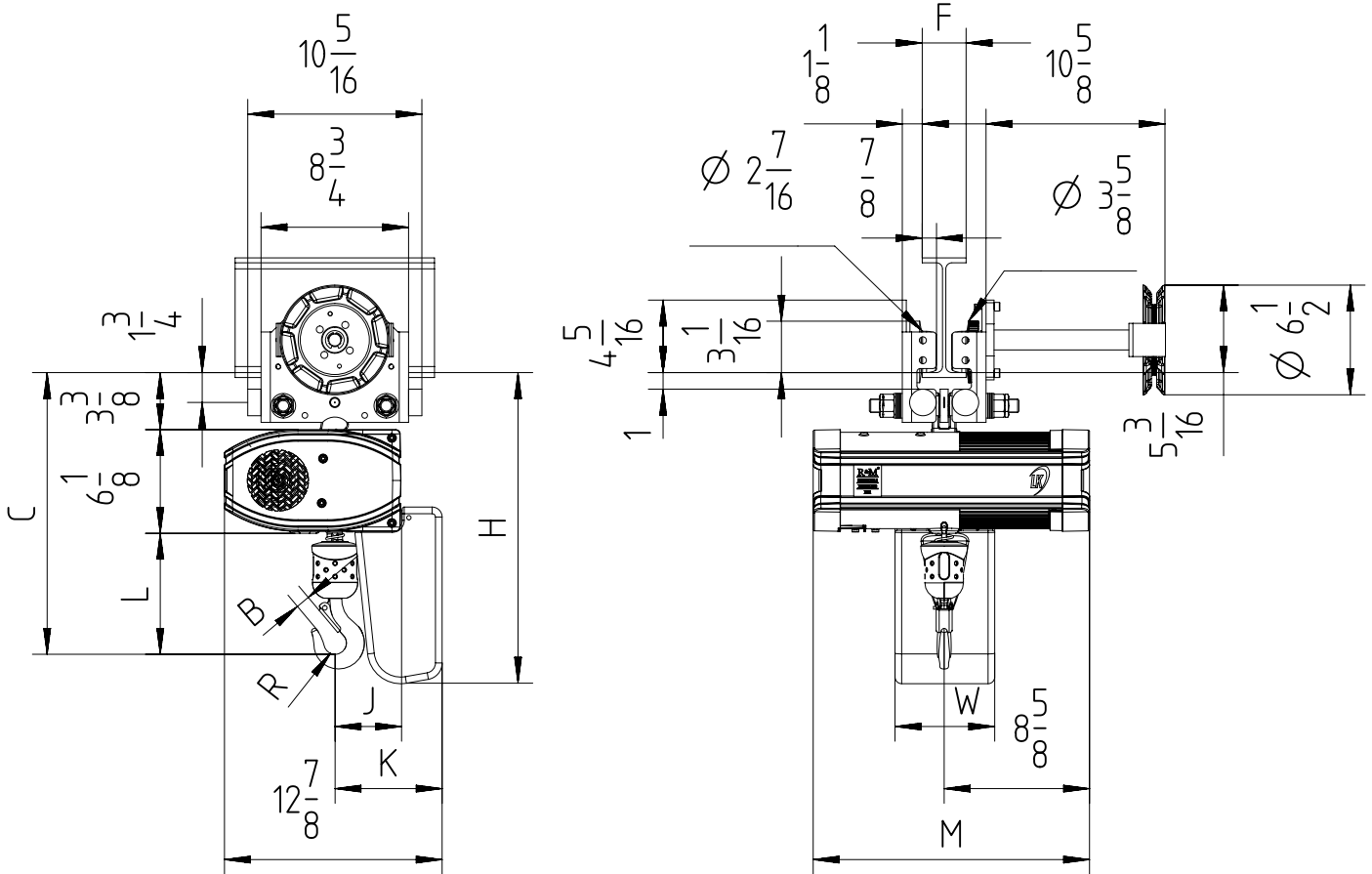

$$2\frac{1}{8} < F < 12\frac{1}{4}$$

Note: Mini. radius of curve for C1 trolley is 6.56ft.

Chain Size (mm)	Max load (TON)	Falls	Chain bag capacity (ft)	Dimensions (inch)										Weight of chain (lb/ft)	Estimated weight of hoist incl. trolley w/o chain (lb)			
				B	C	L	R	J	K	H	W	M			LK	LK Inverter	GLS	DB
												LK	Inverter/DB/GLS					
5X14	1/2	1	19	7/8	16 3/4	7 1/8	5/8	4	6 3/8	18 3/8	5 7/8	16 3/8	21 5/8	0.38	104	123	112	117
			52							21								
			82							25 3/4								

GLS: Gear Limit Switch
DB: Double Brake