

Hook suspended (perpendicular version)

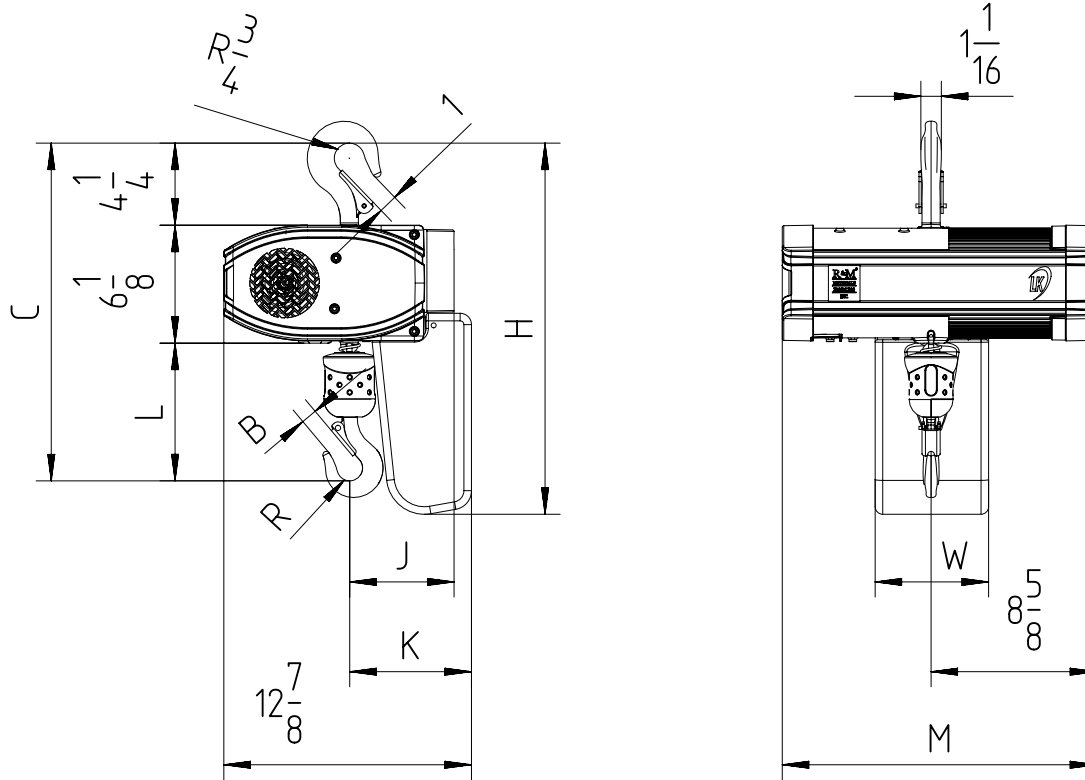

Chain Size (mm)	Max load (TON)	Falls	Chain bag capacity (ft)	Dimensions (inch)										Weight of chain (lb/ft)	Estimated weight of hoist w/o chain (lb)			
				B	C	L	R	J	K	H	W	M			LK	LK Inverter	GLS	DB
												LK	LK Inverter/DB/GLS					
5X14	1/2	1	19	7/8	17 1/2	7 1/8	5/8	5 3/8	6 3/8	19 1/4	5 7/8	16 3/8	21 5/8	0.38	84	104	93	97
			52							21 3/4								
			82							26 1/2								

 GLS: Gear Limit Switch
 DB : Double Brake