

Hook suspended (perpendicular version)

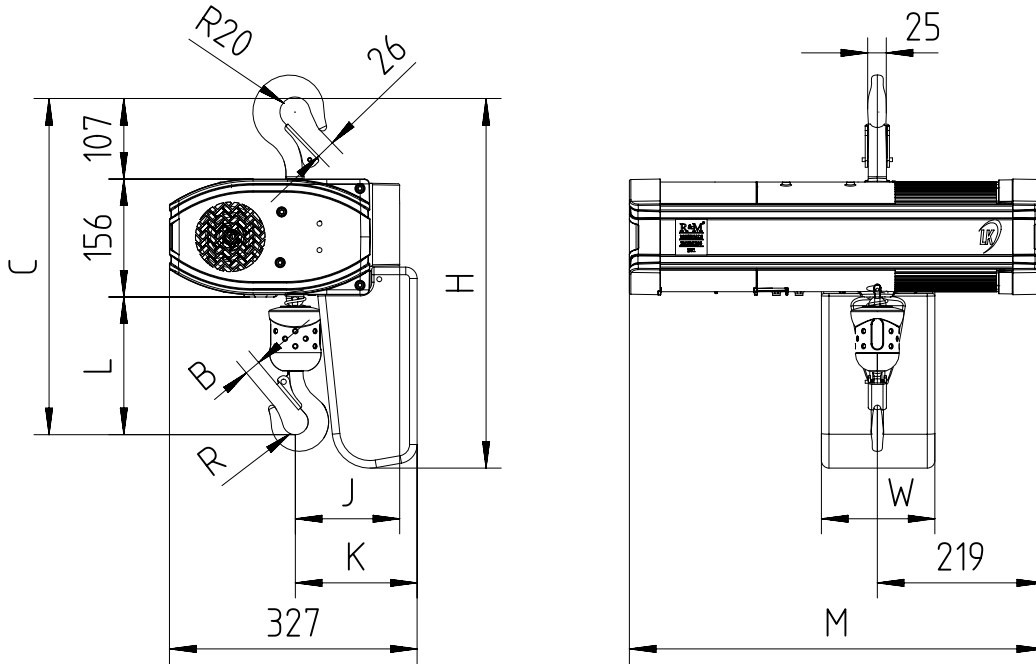

Note: In case of 2-fall hoist, hook suspension is rotated by 180°.

Chain Size (mm)	Max load (kg)	Falls	Chain bag capacity (m)	Dimensions (mm)								Weight of chain (kg/m)	Estimated weight of hoist w/o chain (kg)	
				B	C	L	R	J	K	H	W			M
5X14	630	1	6	21	445	182	17	138	161	489	150	548	0.57	1ph
			16							554				
			25							674				
	1000	2	6 (*)	27	506	243	21	123 (**)	184	489				
			16 (*)							554				
			25 (*)							674				

(*) In case of 2-fall hoist, available lifting height is half of the chain bag maximum capacity
 (**) In case of 2-fall hoist, Counter weight is not needed