

Hook suspended - 1 Fall (perpendicular version)

MAX 1/2 Ton

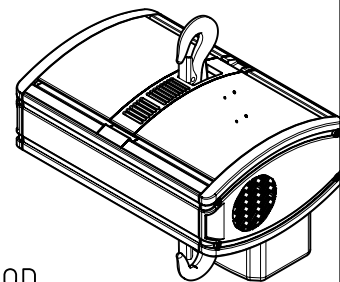
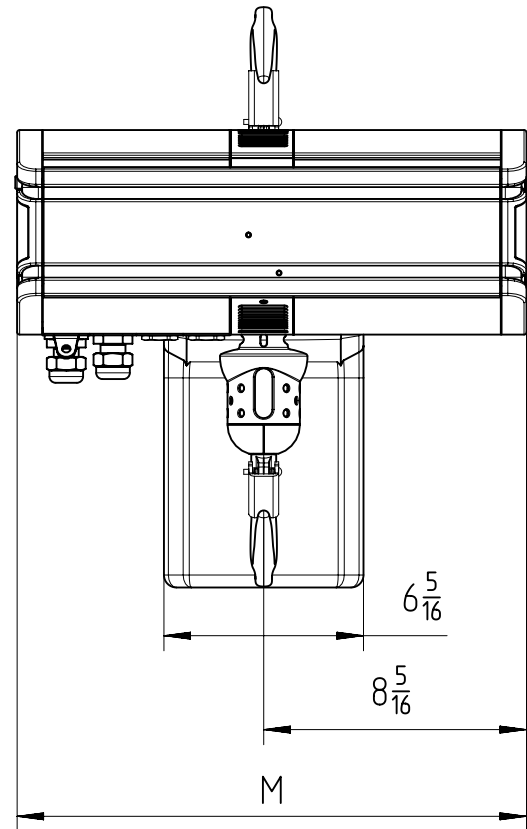
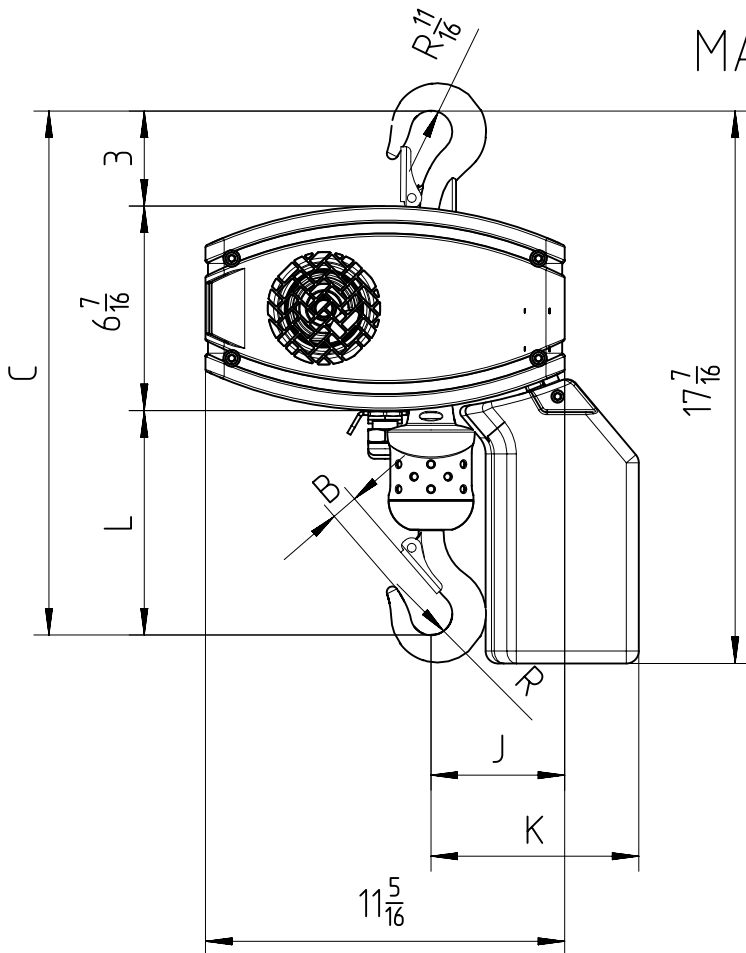

Note: For hoisting speed 63 ft/min or higher, maximum load is 1/4 ton and chain size is 4x11, add 2 1/2 inches to dimension C and L.

Chain Size	Max load Ton	Chain bag capacity ft	Dimensions in inches						Chain weight per foot lb/ft	Estimated Unit weight w/o chain lb			
			B	C	L	R	J	K		LK	LK Inverter	GLS	DB
5x14	1/2	26.2	13/16	16 9/16	7 1/16	11/16	4 3/16	6 9/16	0.4	66.4	74.9	71.2	68.8
4x11	1/4	39.4	3/4	15 9/16	6 1/8	9/16	4 5/16	6 5/8					
Dimension M in inches										16 1/16	20 7/8	19 5/8	17 1/4

 GLS: Gear Limit Switch
 DB : Double Brake