

Fixed to inverter travel trolley TMU2 - 1 Fall (perpendicular version)

Max 500 Kg

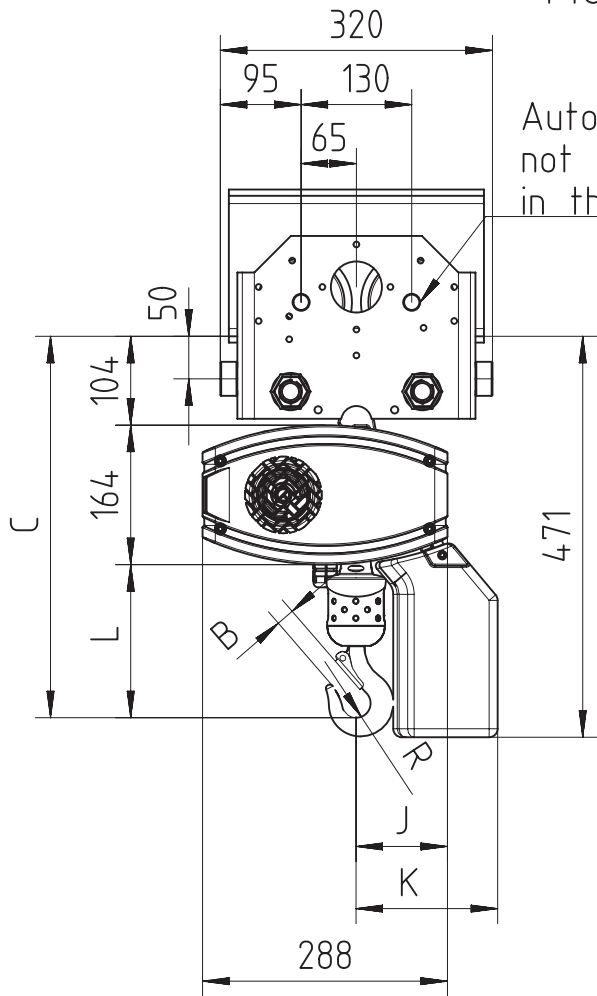

Auto-transformer not shown in this view

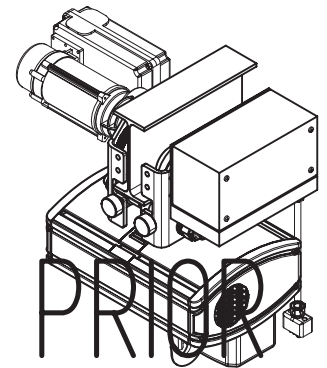
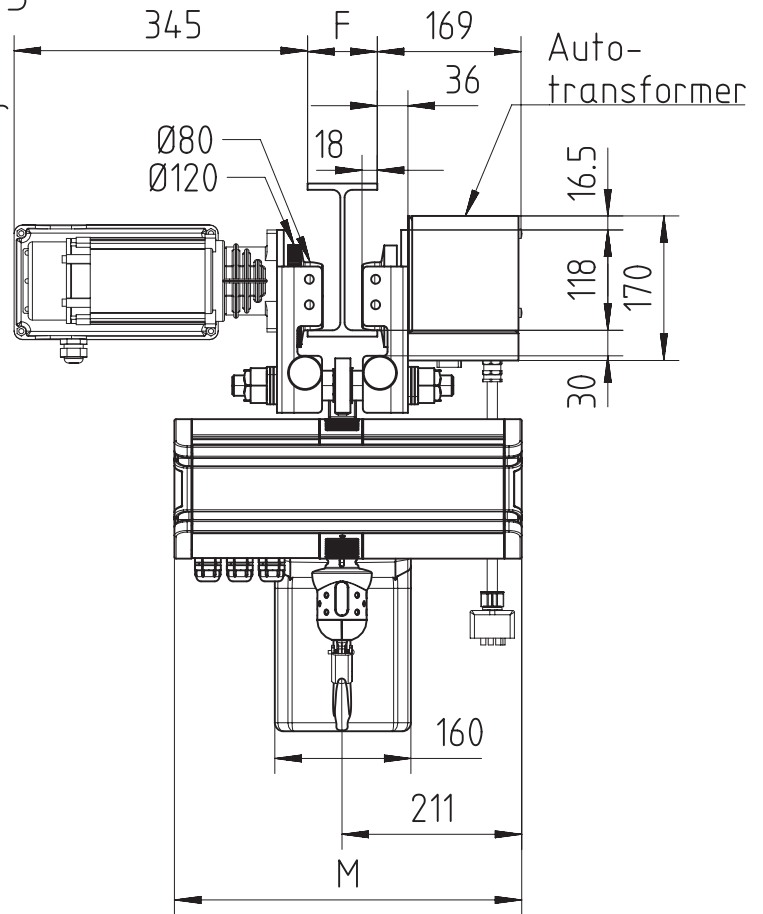

$55 < F < 310$

DISCLOSED WITHOUT PRIOR

Note: For hoisting speed 16 m/min or higher, maximum load 250 Kg and chain size is 4x11, add 63 mm to dimension C and L.

Chain Size	Max load Kg	Chain bag capacity m	Dimensions in mm						Weight per meter Kg/m	Estimated unit weight wo chain Kg			
			B	C	L	R	J	K		LK	LK Inverter	GLS	DB
5x14	500	8	21	428	180	17	107	167	0.57	54.6	58.5	56.8	55.7
4x11	250	12	19	404	156	15	109	169	0.37				
Dimension M in mm										408	531	498	438

GLS: Gear Limit Switch
DB : Double Brake