

Fixed to inverter travel trolley TMU2- 1 Fall (perpendicular version)
 MAX 1/2 Ton

Auto Transformer not shown in this view

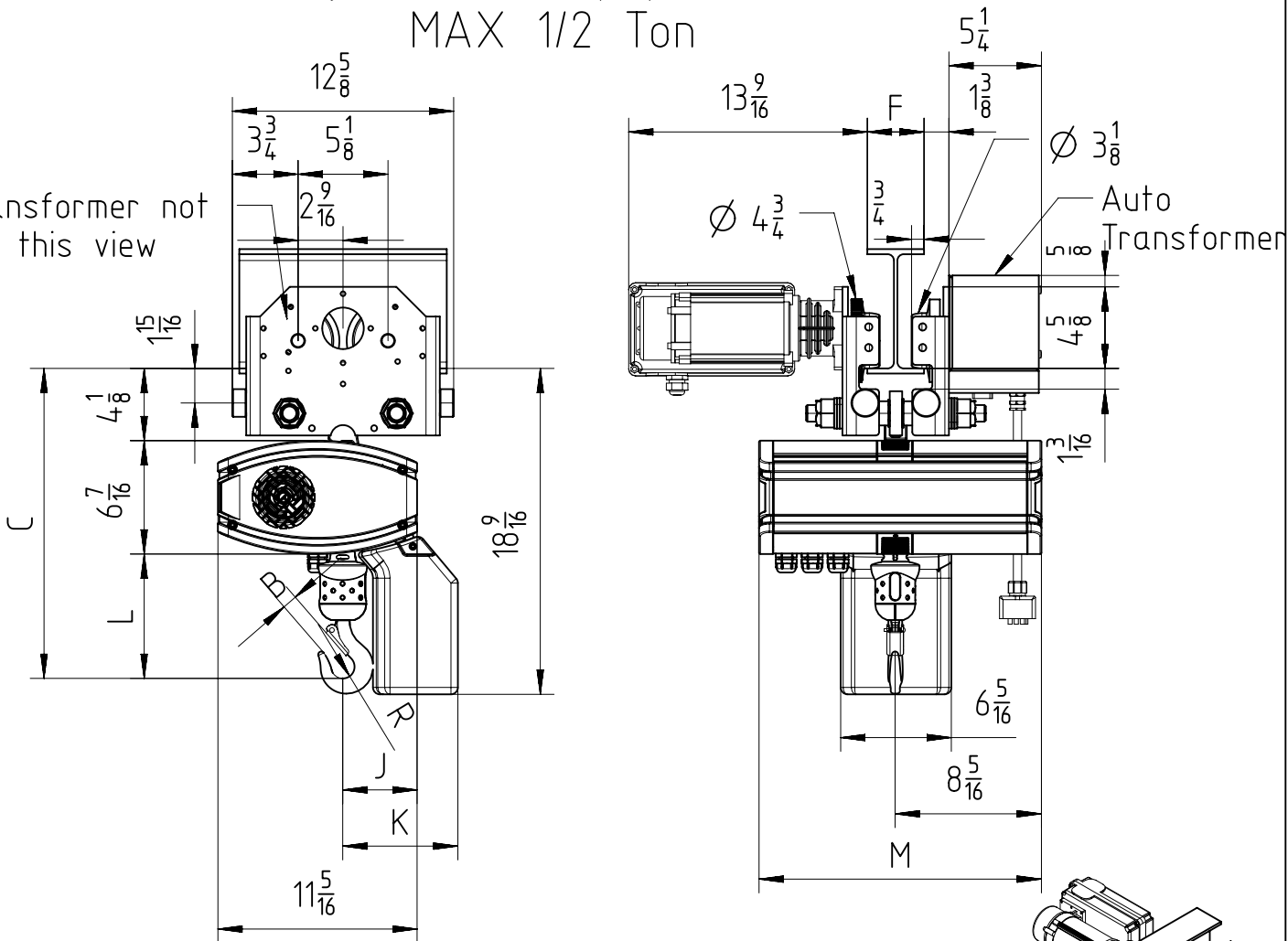

$$2\frac{3}{16} < F < 12\frac{3}{16}$$

Note: For hoisting speed 63 ft/min or higher, maximum load is 1/4 ton and chain size is 4x11, add 2 1/2 inches to dimension C and L.

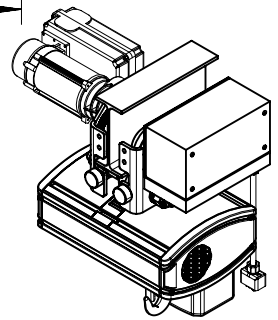

Chain Size	Max load Ton	Chain bag capacity ft	Dimensions in inches						Chain weight per foot lb/ft	Estimated Unit weight w/o chain lb			
			B	C	L	R	J	K		LK	LK Inverter	GLS	DB
5x14	1/2	26.2	13 1/16	17 11/16	7 1/16	11 1/16	4 3/16	6 9/16	0.4	120.4	128.9	125.2	122.8
4x11	1/4	39.4	3 1/4	16 11/16	6 1/8	9 1/16	4 5/16	6 5/8	0.24				
Dimension M in inches									16 1/16	20 7/8	19 5/8	17 1/4	

 GLS: Gear Limit Switch
 DB : Double Brake