

Eye suspended - 1 Fall (perpendicular version)

MAX 1000 Kg

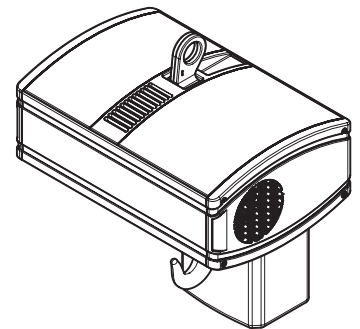
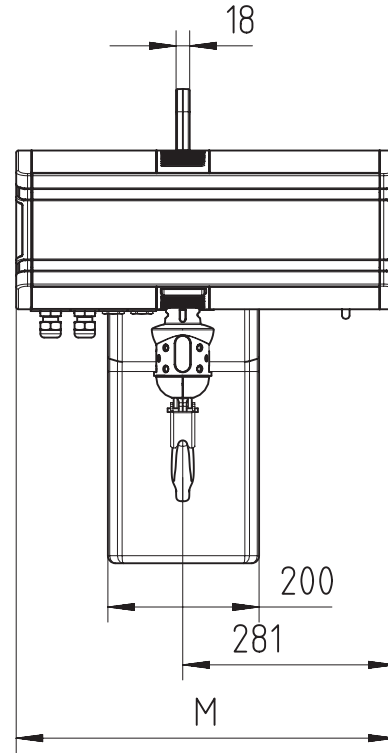
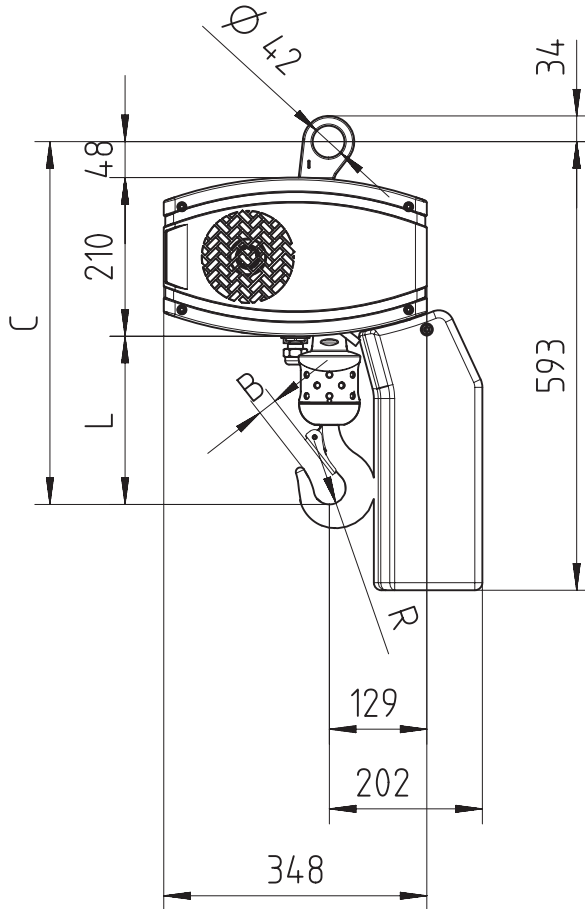

Note: For hoisting speed 16 m/min and higher, add 63 mm to dimension C and L.

Chain Size	Max load kg	Chain bag capacity m	Dimensions in mm				Weight per meter of chain Kg/m	Estimated unit weight w/o chain Kg			
			B	C	L	R		LK	LK Inverter	GLS	DB
7X20	1000	10	28	480	223	21	1.10	50.1	55.6	54.6	52.8
Dimension M in mm								501	615	590	539

 GLS: Gear Limit Switch
 DB : Double Brake