

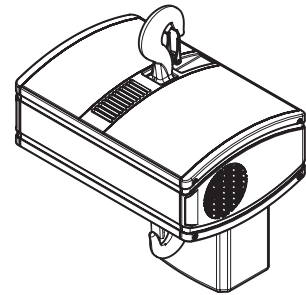

Hook suspended - 1 Fall (perpendicular version)

MAX 1 Ton

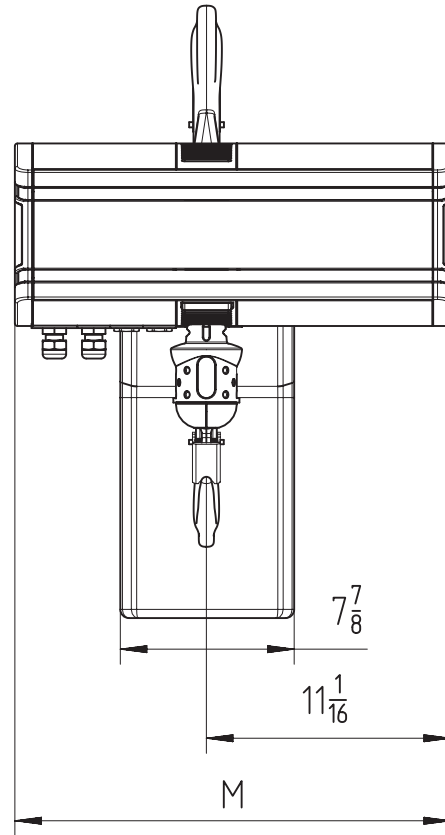
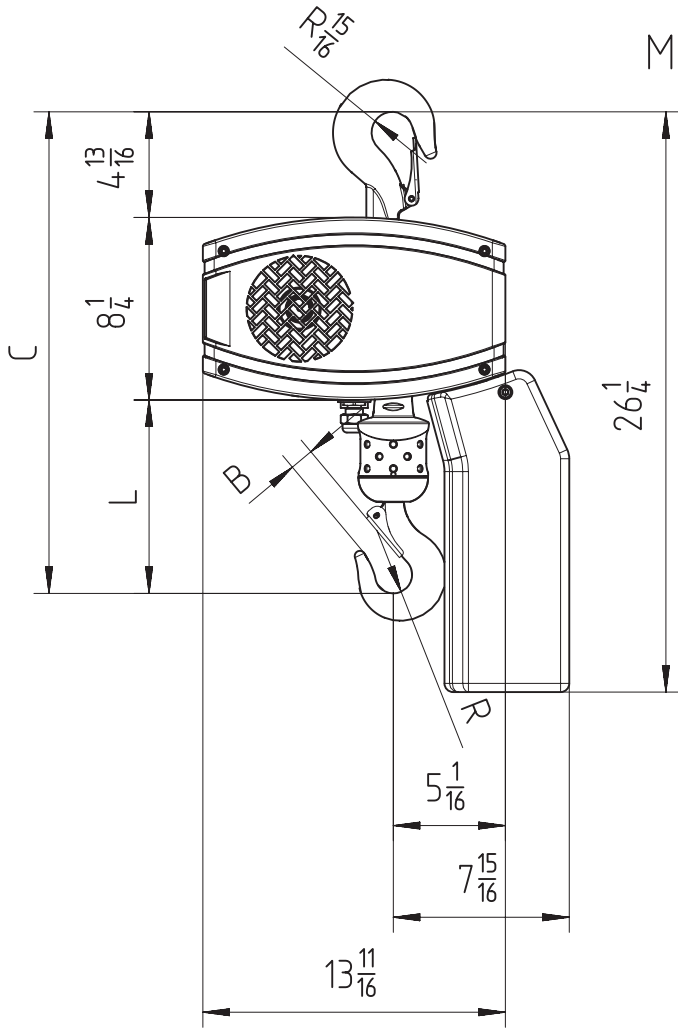

Note: For hoisting speed 63 ft/min and higher, add  $2\frac{1}{2}$  inches to dimension C and L.

Chain Size	Max load Ton	Chain bag capacity ft	Dimensions in inches				Chain weight per foot lb/ft	Estimated Unit weight w/o chain lb			
			B	C	L	R		LK	LK Inverter	GLS	DB
7x20	1	32.8	$1\frac{1}{8}$	$21\frac{13}{16}$	$8\frac{3}{4}$	$\frac{13}{16}$	0.75	113.3	125.4	123	119.3
Dimension M in inches								$19\frac{3}{4}$	$24\frac{3}{16}$	$23\frac{1}{4}$	$21\frac{1}{4}$

GLS: Gear Limit Switch  
DB : Double Brake