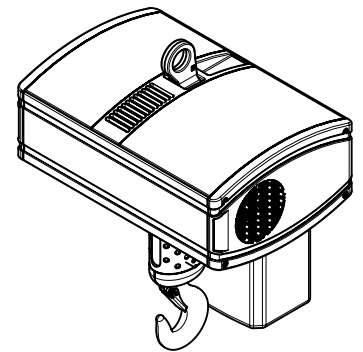
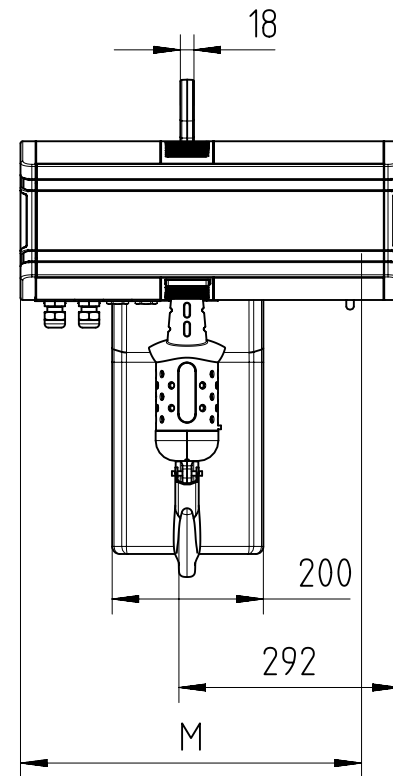
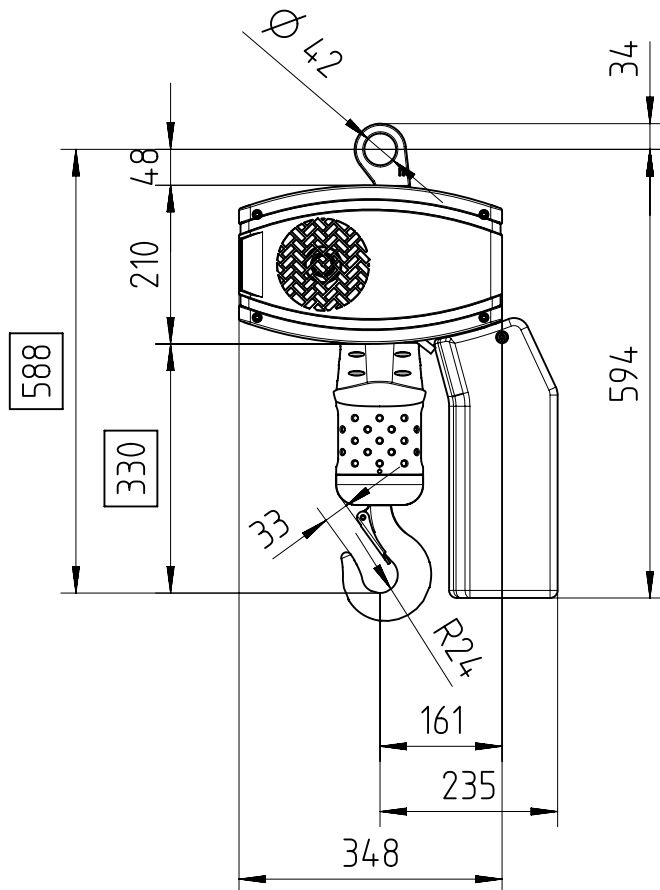

Eye suspended - 2 falls (perpendicular version)

MAX 2000 Kg

 Note: For hoisting speed 16 m/min and higher, add 63 mm to dimension **588** and **330**.

Chain Size	Max load kg	Chain bag capacity m	Weight per meter of chain Kg/m	Estimated unit weight w/o chain Kg			
				LK	LK Inverter	GLS	DB
7X20	2000	10	1.10	54.9	59.0	58.0	56.2
Dimension M in mm				501	615	590	539

 GLS: Gear Limit Switch  
 DB : Double Brake