

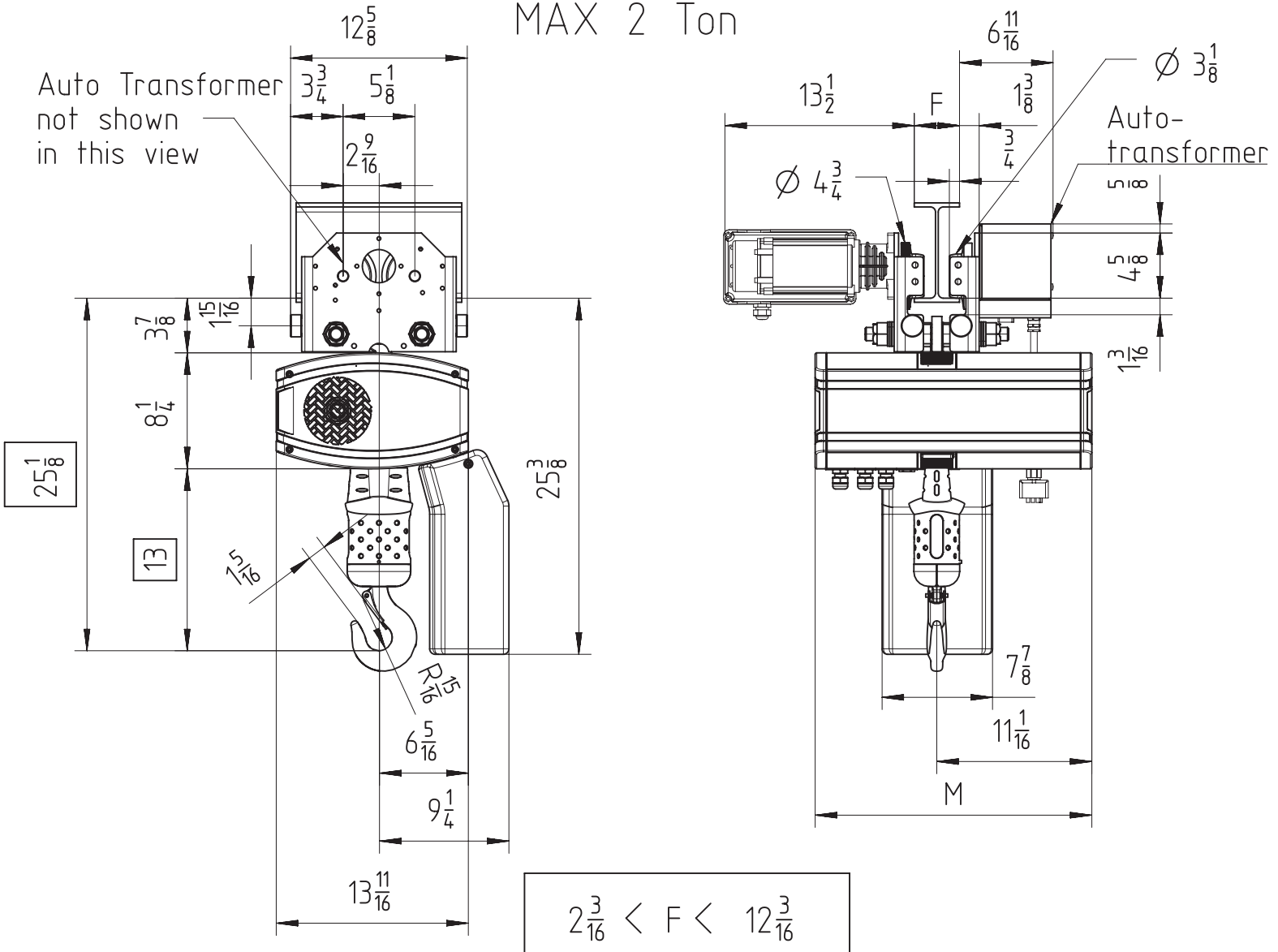

Fixed to inverter or two-speed travel trolley TMU2 - 2 falls (perpendicular version)

MAX 2 Ton



Note:

- 1) For two-speed trolley Auto-transformer and its dimensions not applicable.
- 2) For hoisting speed 63 ft/min and higher, add 2 1/2 inches to dimension 25 1/8 and 13.

Chain Size	Max load Ton	Chain bag capacity ft	Chain weight per foot lb/ft	Estimated Unit weight w/o chain lb			
				LK	LK Inverter	GLS	DB
7x20	2	32.8	0.75	199.3	208.3	203.4	202.2
Dimension M in inches				19 3/4	24 3/16	23 1/4	21 1/4

GLS: Gear Limit Switch  
DB : Double Brake

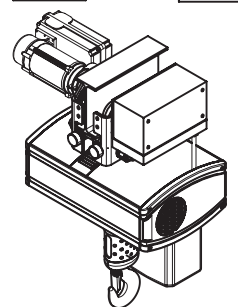

53093825  
D171581-A  
13/03/2013