

Fixed to electric travel trolley C2 max 2000kg (perpendicular version)

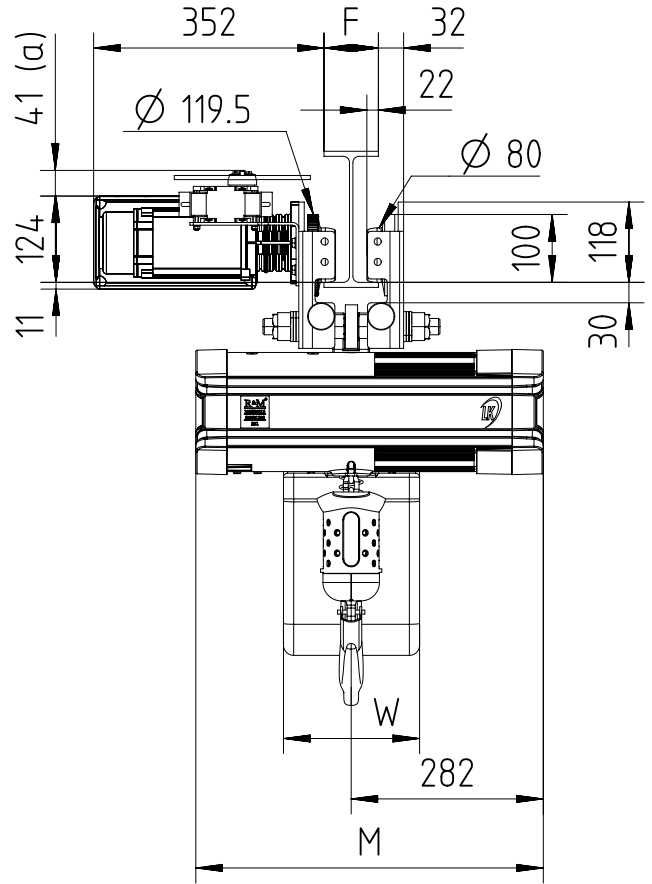
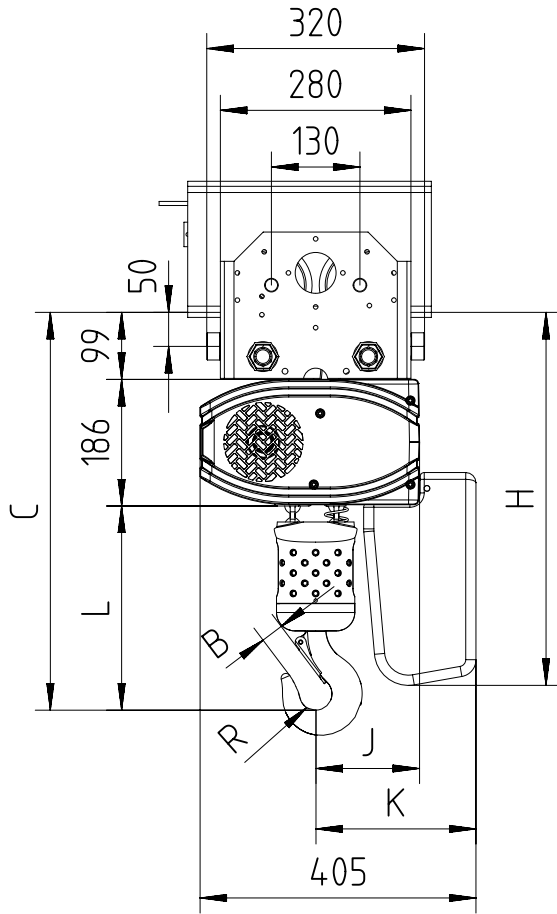

$$64 < F < 310$$

(a) Note: Trolley limit switch is optional.
 Note: In case of 1-fall hoist, coupling suspension is rotated by 180°.
 Note: Mini. radius of curve for trolley 2000 kg is 2m.

Chain Size (mm)	Max load (kg)	Falls	Chain bag capacity (m)	Dimensions (mm)										Weight of chain (kg/m)	Estimated weight of hoist incl. trolley w/o chain (kg)			
				B	C	L	R	J	K	H	W	M			LK	LK Inverter	GLS	DB
												LK	LK Inverter/DB/GLS					
7X20	1250	1	6	27	515	230	21	150 (**)	205	548	200	510	641	1.1	89	98	91	98
			16							689								
			30							759								
	2000	2	6 (*)	33	585	300	24	154	236	548	200	510	641	1.1	84	93	86	93
			16 (*)							689								
			30 (*)							759								

GLS: Gear Limit Switch
 DB: Double Brake

(*) In case of 2-fall hoist, available lifting height is half of the chain bag maximum capacity.
 (**) In case of 1-fall hoist, Counter weight is needed.