

Fixed to electric travel trolley C3 max 2.5 TON (perpendicular version)

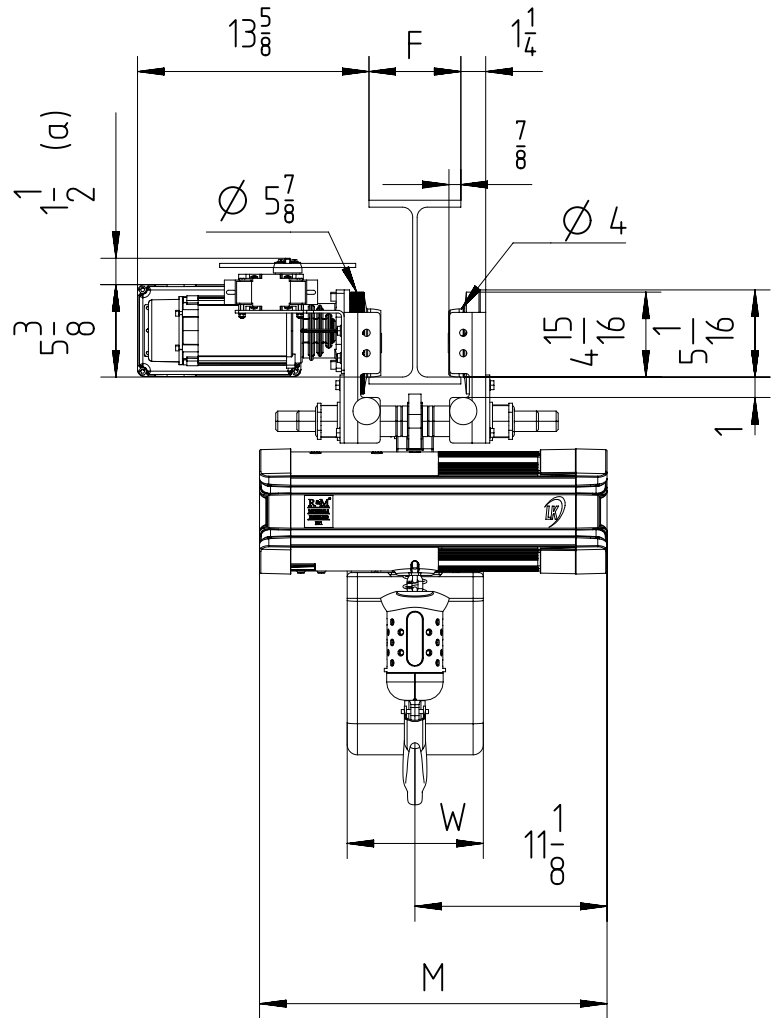
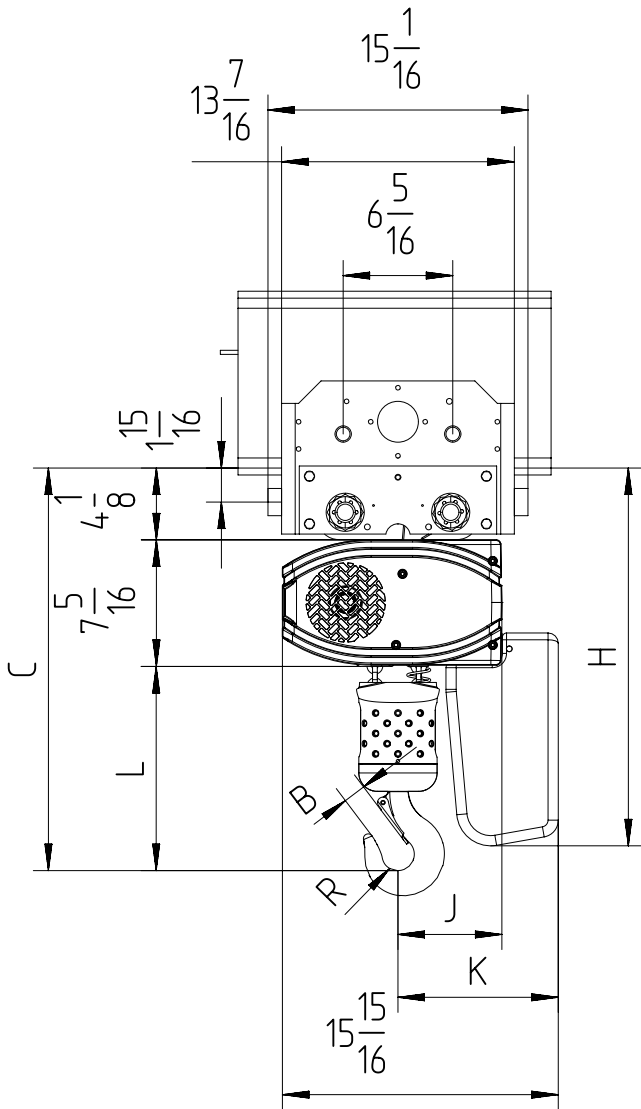

$$3\frac{1}{4} < F < 12\frac{3}{16}$$

(a) Note: Trolley limit switch is optional.
 Note: Mini. radius of curve for trolley 2.5 TON is 6.56ft.

Chain Size (mm)	Max load (TON)	Falls	Chain bag capacity (ft)	Dimensions (inch)										Weight of chain (lb/ft)	Estimated weight of hoist incl. trolley w/o chain (lb)			
				B	C	L	R	J	K	H	W	M			LK	LK Inverter	GLS	DB
												LK	LK Inverter/DB/GLS					
7X20	2 $\frac{1}{2}$	2	19 (*)	1 $\frac{1}{4}$	23 $\frac{1}{4}$	11 $\frac{3}{4}$	1	6	9 $\frac{1}{4}$	21 $\frac{7}{8}$	7 $\frac{7}{8}$	20 $\frac{1}{16}$	25 $\frac{1}{4}$	0.75	231	251	236	251
			52 (*)							27 $\frac{3}{8}$								
			98 (*)							30 $\frac{1}{8}$								

GLS: Gear Limit Switch
 DB: Double Brake

(*) In case of 2-fall hoist, available lifting height is half of the chain bag maximum capacity