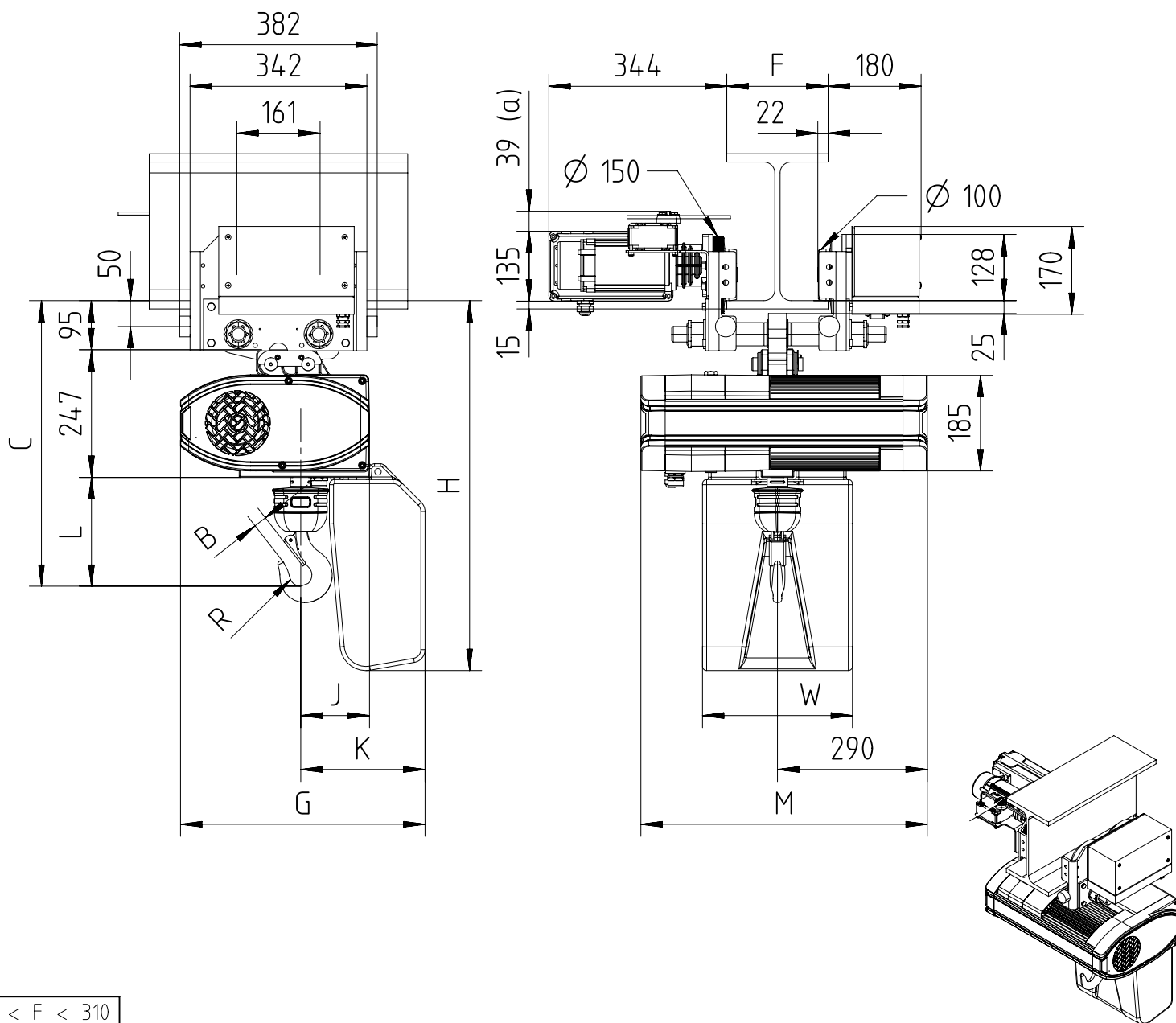

Fixed to electric travel trolley TMU-C3 max 3200Kg (perpendicular version)

 $82 < F < 310$

(a) Note: Trolley limit switch is optional.
 Note: In case of 2-fall hoist, coupling suspension is rotated by 180°.
 Note: Mini. radius of curve for trolley 3200 Kg is 2m.
 Note: Add 60mm to C & L dimension for hoisting speeds greater than 8 m/min.

Chain Size (mm)	Max load (Kg)	Falls	Chain bag capacity (m)	Dimensions (mm)										Weight of chain (kg/m)	Estimated weight of hoist incl. trolley w/o chain (Kg)			
				B	C	L	R	J	K	G	H	W	M					
													LK/		GLS	DB	LK	GLS
9x27	1600	1	12	26	552	210	22	133	240	473	716	290	554	668	1.8	139	144	148
			40 (*)						422	655	930	300				143	148	152
	3200	2	12 (**)	35	699	357	25	175	240	473	716	290	554	668	1.8	143	148	152
			40 (*, **)						422	655	930	300				143	148	152

 GLS: Gear Limit Switch
 DB : Double Brake

(*) For these heights of lift, customer has to link the chain bag to the structure.
 (**) In case of 2-fall hoist, available lifting height is half of the chain bag maximum capacity.