

Fixed to hand chain trolley C1 max 320 kg (perpendicular version)

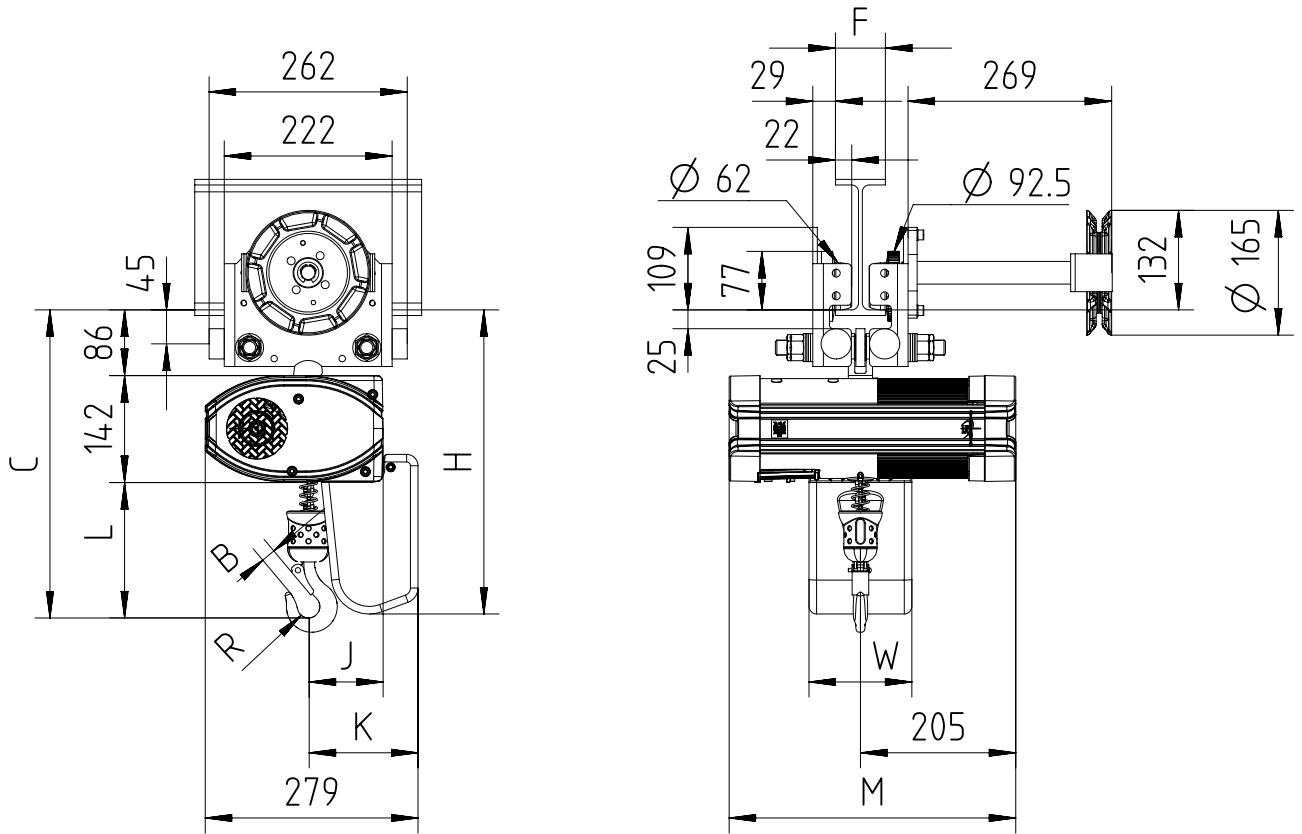

55 < F < 310

Note: Mini. radius of curve for C1 trolley is 2m.

Chain Size (mm)	Max load (kg)	Falls	Chain bag capacity (m)	Dimensions (mm)										Weight of chain (kg/m)	Estimated weight of hoist incl. trolley w/o chain (kg)		
				B	C	L	R	J	K	H	W	M			LK	GLS	DB
												LK	DB/GLS				
4X11	320	1	6	19	407	179	15	99	145	402	136	379	496	0.37	40	46	42
			16							502							
			35							652							

GLS: Gear Limit Switch  
DB: Double Brake