

Fixed to hand cahin trolley C1 max 0.25 TON (perpendicular version)

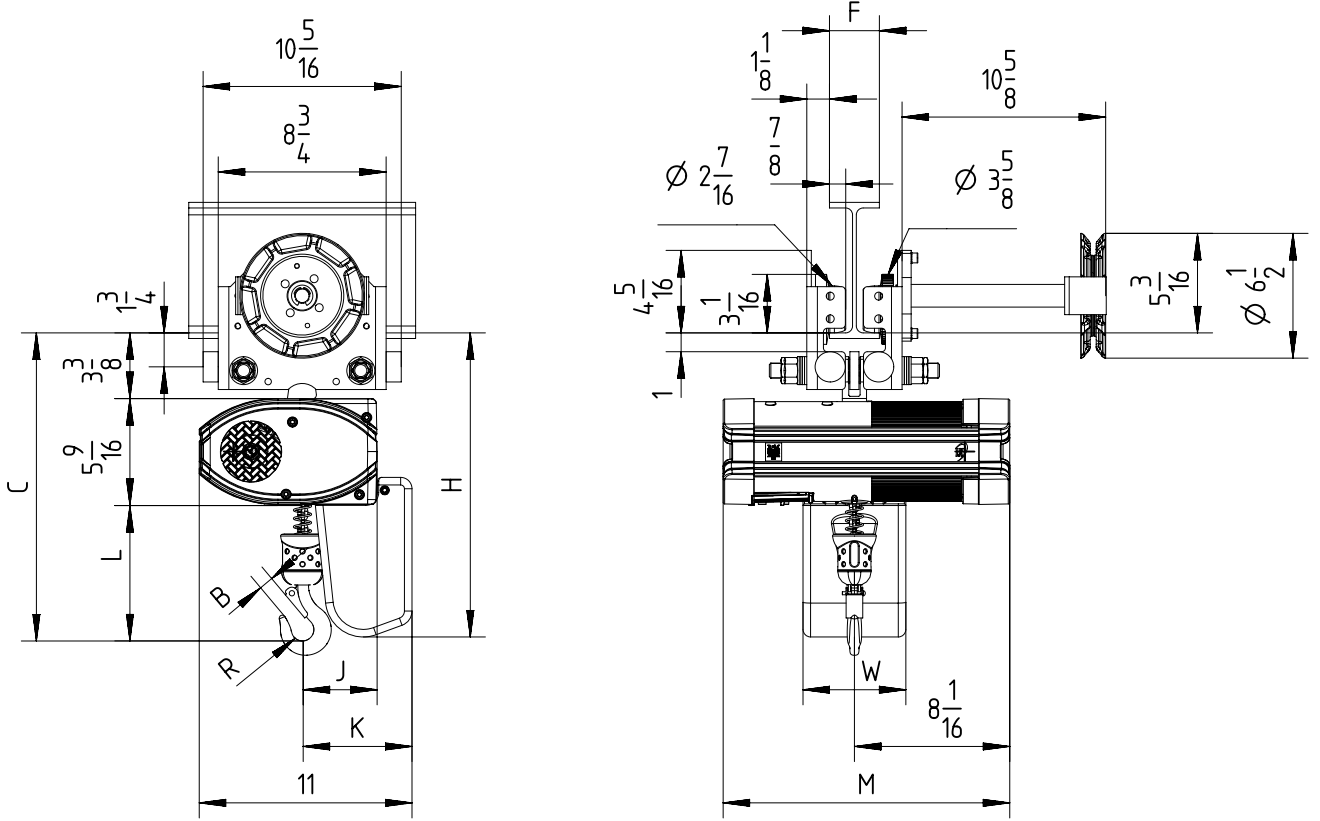

$$2\frac{3}{16} < F < 12\frac{3}{16}$$

Note: Mini. radius of curve for C1 trolley is 6.56ft.

Chain Size (mm)	Max load (TON)	Falls	Chain bag capacity (ft)	Dimensions (inch)										Weight of chain (lb/ft)	Estimated weight of hoist incl. trolley w/o chain (lb)		
				B	C	L	R	J	K	H	W	M			LK	GLS	DB
												LK	DB/GLS				
4X11	1/4	1	19	3/4	16	7	5/8	3 7/8	5 3/4	15 7/8	5 3/8	14 7/8	19 1/2	0.25	88	101	93
			52							19 3/4							
			114							25 5/8							

GLS: Gear Limit Switch
DB: Double Brake