

Fixed to hand chain trolley C5 Max 5000kg (perpendicular version)

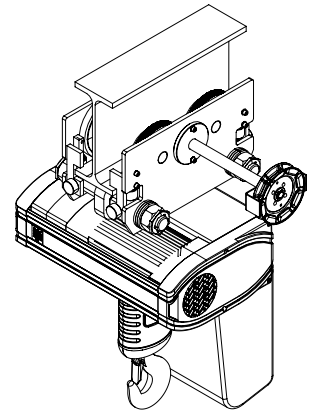
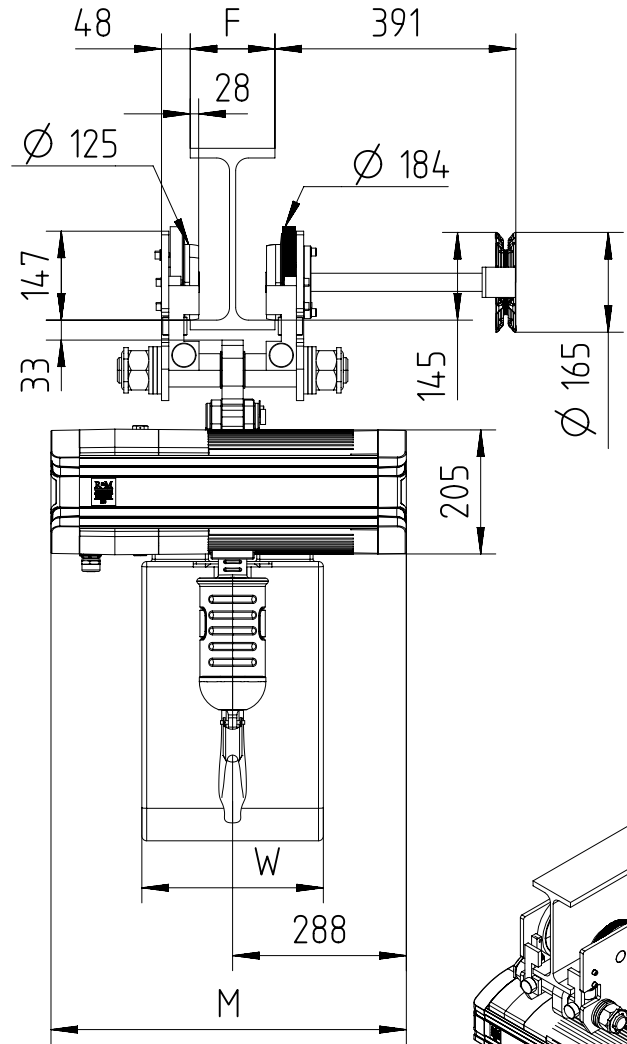
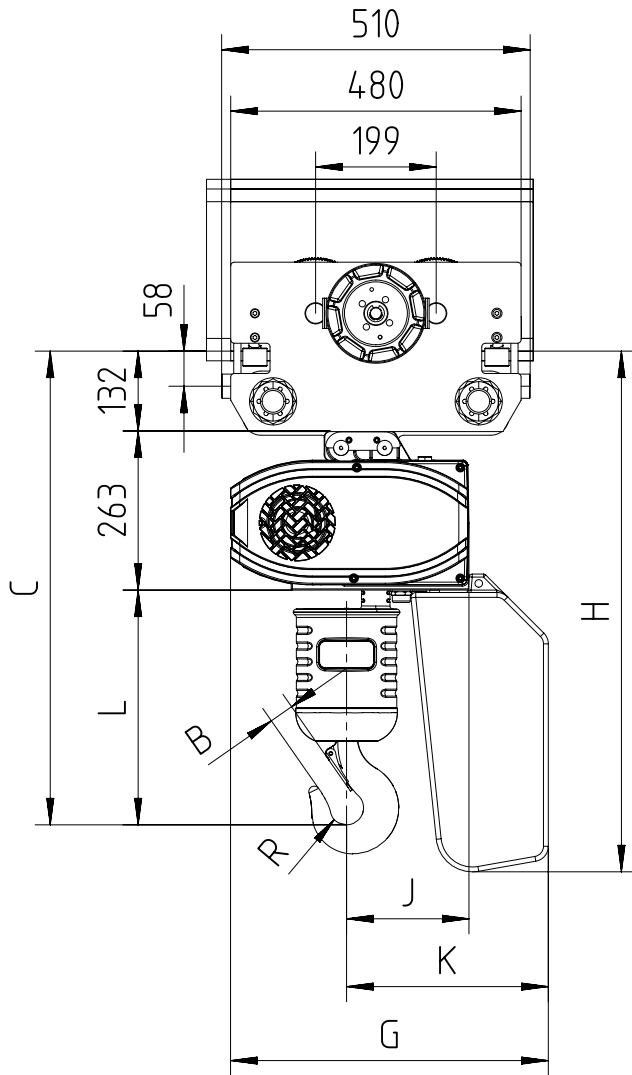

82 < F < 310

Note: Add 60mm to C & L dimension for hoisting speeds greater than 8 m/min.

Chain Size (mm)	Max load (Kg)	Falls	Chain bag capacity (m)	Dimensions (mm)											Weight of chain (kg/m)	Estimated weight of hoist incl. trolley w/o chain (Kg)			
				B	C	L	R	J	K	G	H	W	M			LK	GLS	DB	
													LK/	GLS					DB
11.3X31	5000	2	12 (**)	41	783	388	28	203	334	525	816	300	587	709	2.8	172	177	178	

GLS: Gear Limit Switch
DB : Double Brake

(**) In case of 2-fall hoist, available lifting height is half of the chain bag maximum capacity.