

Fixed to hand chain trolley C3 Max 3 TON (perpendicular version)

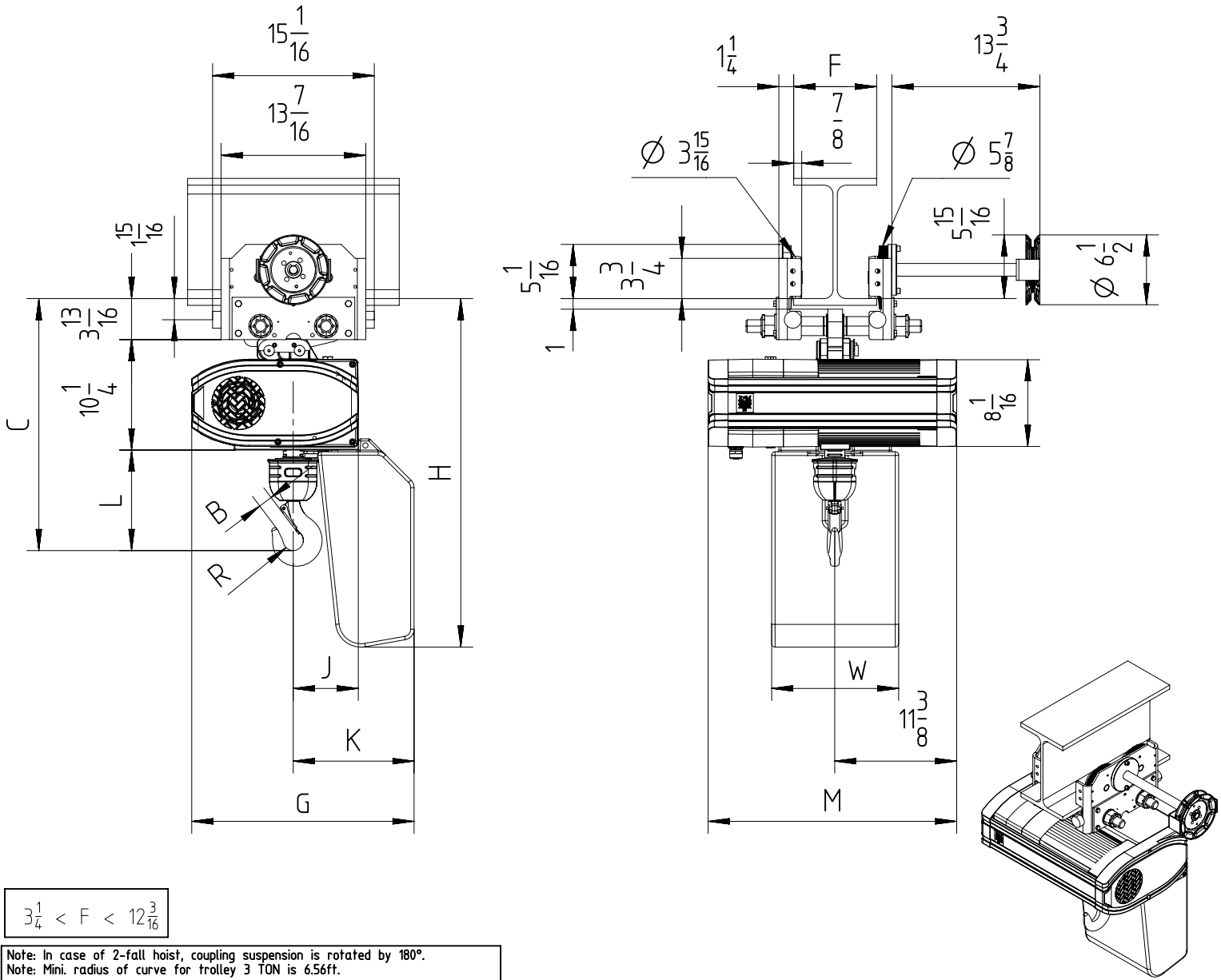

$$3\frac{1}{4} < F < 12\frac{3}{16}$$

Note: In case of 2-fall hoist, coupling suspension is rotated by 180°.
 Note: Mini. radius of curve for trolley 3 TON is 6.56ft.
 Note: Add 2 $\frac{3}{8}$ inch to C & L dimension for hoisting speeds greater than 32 fpm.

| Chain Size (mm) | Max load (TON) | Falls | Chain bag capacity (ft) | Dimensions (inch) | | | | | | | | | | | Weight of chain (lb/ft) | Estimated weight of hoist incl. trolley w/o chain (lb) | | |
|-----------------|-----------------|-------|-------------------------|-------------------|-------------------|------------------|------------------|------------------|-------------------|--------------------|-------------------|--------------------|------------------|--------------------|-------------------------|--|-----|-----|
| | | | | B | C | L | R | J | K | G | H | W | M | | | LK | GLS | DB |
| | | | | | | | | | | | | | LK/GLS | DB | | | | |
| 11.3x31 | 2 $\frac{1}{2}$ | 1 | 39 | 1 $\frac{5}{16}$ | 23 $\frac{7}{16}$ | 9 $\frac{3}{8}$ | 1 $\frac{5}{16}$ | 6 $\frac{1}{16}$ | 11 $\frac{1}{4}$ | 20 $\frac{11}{16}$ | 32 $\frac{7}{16}$ | 11 $\frac{13}{16}$ | 23 $\frac{1}{8}$ | 27 $\frac{15}{16}$ | 1.9 | 324 | 335 | 337 |
| | | | 98 (*) | | | | | | 17 $\frac{7}{16}$ | 26 $\frac{7}{8}$ | 38 $\frac{3}{8}$ | | | | | 333 | 344 | 346 |
| | 3 | 2 | 39 (**) | 1 $\frac{5}{8}$ | 27 $\frac{3}{8}$ | 15 $\frac{1}{4}$ | 1 $\frac{1}{8}$ | 8 | 13 $\frac{1}{8}$ | 20 $\frac{11}{16}$ | 32 $\frac{7}{16}$ | 11 $\frac{13}{16}$ | 23 $\frac{1}{8}$ | 27 $\frac{15}{16}$ | 1.9 | 333 | 344 | 346 |
| | | | 65 (*,**)) | | | | | | 19 $\frac{7}{16}$ | 26 $\frac{7}{8}$ | 38 $\frac{3}{8}$ | | | | | 333 | 344 | 346 |

GLS: Gear Limit Switch
 DB : Double Brake
 (*) For big height of lift, customer has to link the chain bag to the structure.
 (**) In case of 2-fall hoist, available lifting height is half of the chain bag maximum capacity.

R&M reserves the right to alter or amend the above information without notice.

DISCLOSED WITHOUT PRIOR WRITTEN CONSENT OF THE COMPANY . ANY COPIES OF THIS DOCUMENT MADE BY ANY METHOD MUST ALSO INCLUDE A COPY OF THIS LEGEND.