

Dimensions are for reference in estimating only. Use of various modifications may affect overall dimensional outline. Where dimensions are critical, request certified drawings for construction. All dimensions are in millimeters unless otherwise noted.

**The maximum wheel loads listed are only a guideline. The maximum values are based on assumption that the crane speed is 40 m/min (130 fpm), end truck duty is Fem 2m and the runway rail width is 80 mm (3.15"). If these conditions change, use QuoteMaster to help select the end truck.

For joint plate details, refer to drawing:

TOP JOINT PLATE TYPE K

SIDE JOINT PLATE TYPE S

End truck shown without joint plate.

| BUMPER DIMENSIONS | |
|-------------------|-----|
| TYPE | L1 |
| | mm |
| B | 68 |
| C | 85 |
| D | 105 |
| E | 150 |
| F | 190 |
| H | 160 |
| I | 200 |
| M | 125 |
| P | 240 |
| S | 300 |

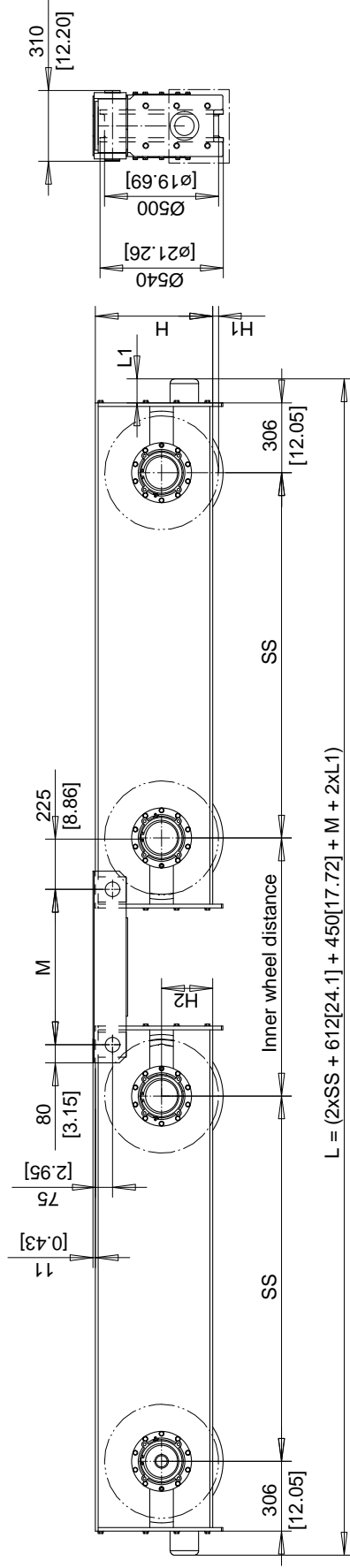
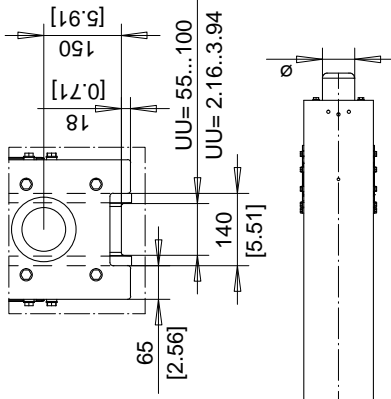

TOTAL WGT = WGT/TRK*2 + M*80 kg/m [4.48 lb/in]
 TOTAL WGT IS FOR ONE-HALF SET FOR CRANE

COMPATIBLE WITH GES5 DRIVE

1600 mm WHEEL BASE END TRUCK SHOWN

RT END TRUCKS

| SS | mm [inch] | H | mm [inch] | H1 | mm [inch] | H2 | mm [inch] | Max. dynamic whl load kN(kip)* | WG/T/TRK | | p_RT50B File | |
|------|-----------|-----|-----------|----|-----------|-----|-----------|--------------------------------|----------|---------|-----------------|----------------------------|
| | | | | | | | | | kg [lb] | kg [lb] | | |
| 1600 | [63] | 514 | [20.24] | 26 | [1.02] | 224 | [8.82] | 350 | [78.75] | 410 | [904] | RT50B |
| 1800 | [70.9] | 514 | [20.24] | 26 | [1.02] | 224 | [8.82] | 350 | [78.75] | 450 | [992] | R&M MATERIAL HANDLING, INC |
| 2000 | [78.7] | 514 | [20.24] | 26 | [1.02] | 224 | [8.82] | 350 | [78.75] | 490 | [1080] | SPRINGFIELD, OH USA |
| | | | | | | | | | | | RT50B END TRUCK | Issue 3/2006 |