

MEDIUM CONNECTION

MIN 5 1/2"

SPAN

MIN 5 1/2"

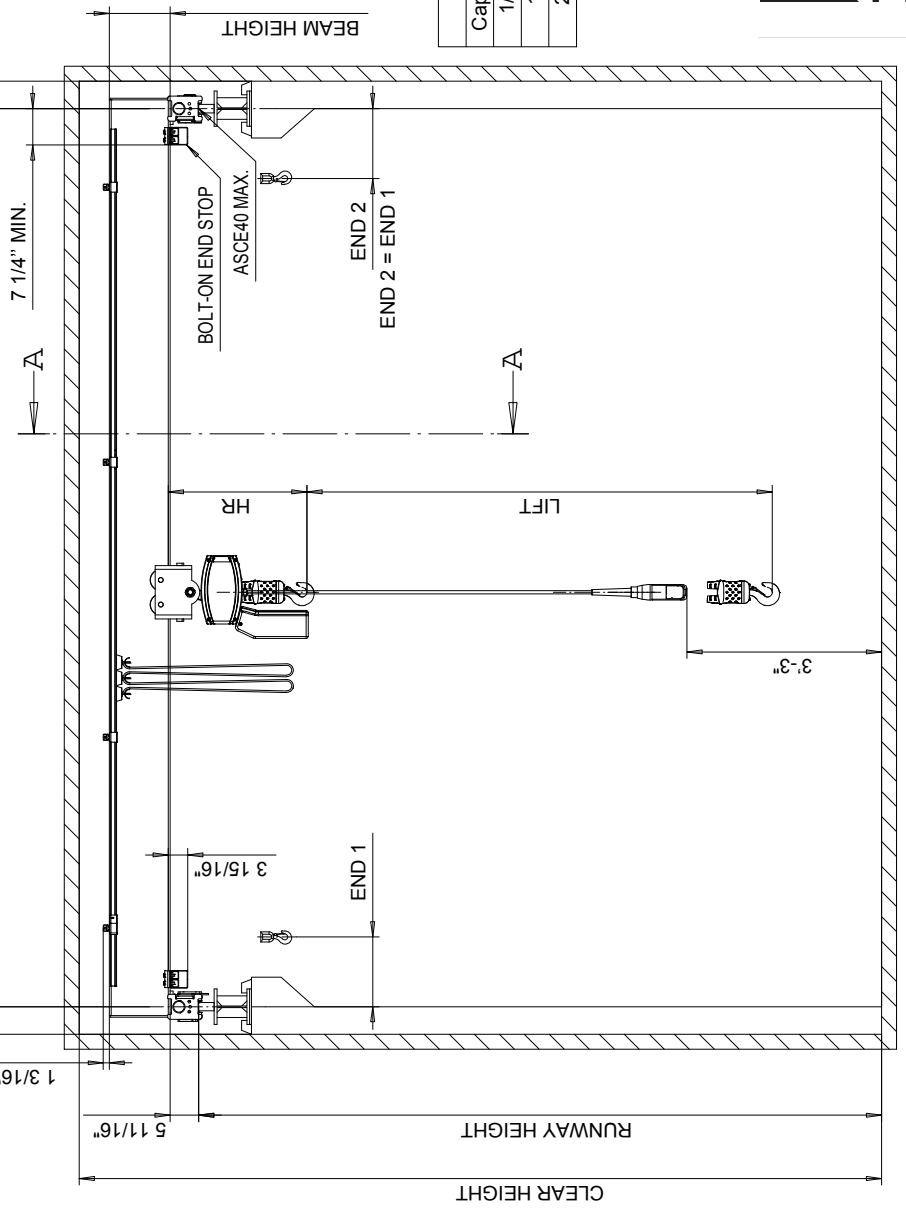
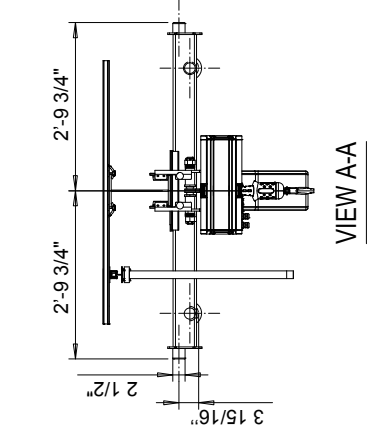

Capacity	Hoist	HR	STD	MED
1/2 T	LK05 C - 1 fall	17 3/4"	END 2 13 1/4"	END 4 21"
1 T	LK10 C - 1 fall	23"	14"	21 3/4"
2 T	LK10 C - 2 fall	28"	14"	22 5/8"



QLP SGTR PUSH CRANE