

FOOT MOUNT, 4 PART SINGLE

Hoist type:

SX2 041..F0

SX3 041..F0

SI-60Hz

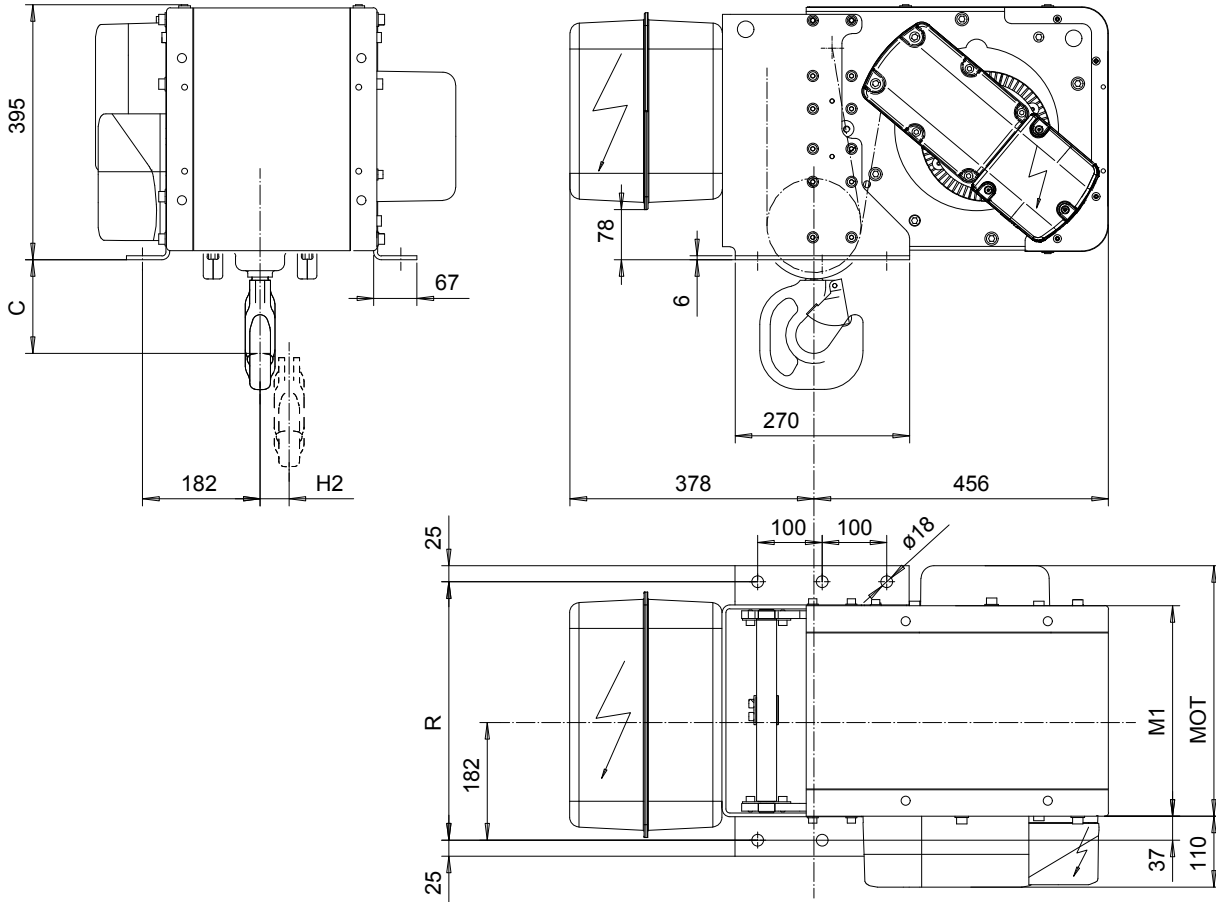

Motor	P1	P2	P3	A3	S3
MOT (mm)	385	446	476	446	526
Weight (kg)	21	31	35	32	28

HOL	Length	M1	H2	R	Approx Weight
(m)	code	(mm)	(mm)	(mm)	(kg)
6	A	326	45	400	125
9.5	C	456	72	530	135

Headroom - C dimension	
Standard	145 mm
with HS22 Hook operated limit switch	375 mm

Load	Class
(kg)	Fem/ISO
1600	3m/M6
2000	2m/M5
2500	3m/M6
3200	2m/M5

Approx. weight calculated with P1 motor.

This document is the absolute property of R&M Materials Handling, Inc. This document must not be copied without the written permission of R&M Materials Handling, Inc. The contents thereof must not be disclosed to a third party nor be used for any unauthorized purpose. Contravention will be prosecuted.

Design	Chd	Appd	Ref Drawing	QA-F-04
Date	HOIST; FIXED			1:5 Folder
SLEIGHCE Owner Dept	4 ROPE FALLS			
R&M MATERIALS HANDLING INC.	R&M MATERIALS HANDLING, INC. HOIST & CRANE PRODUCTS SPRINGFIELD, OHIO			Issue 8
D002078-A				