

LOW HEADROOM, 2 PART SINGLE

Hoist type:

SX4 021...L0

SI

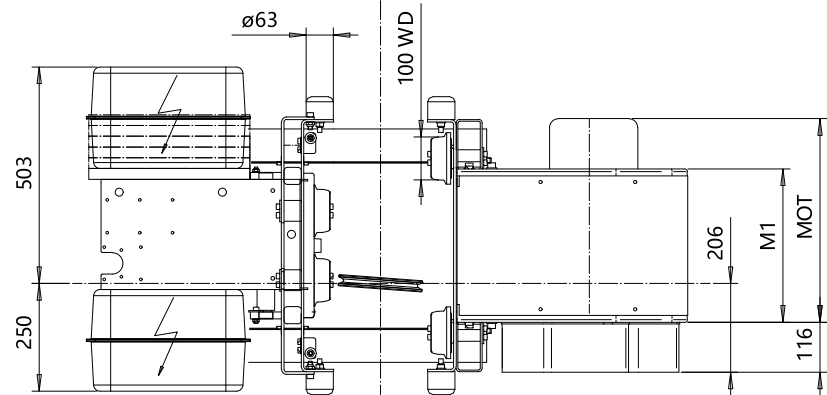
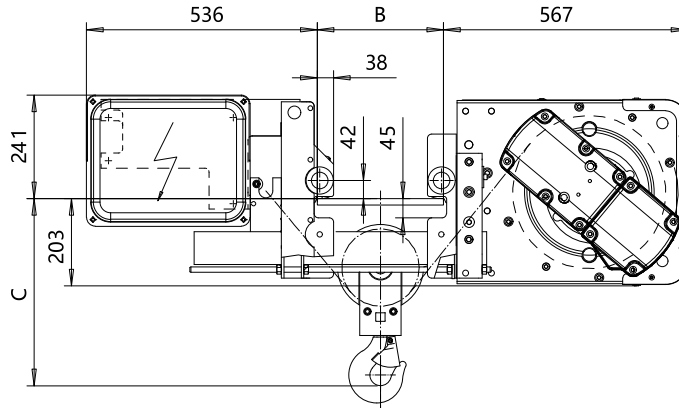
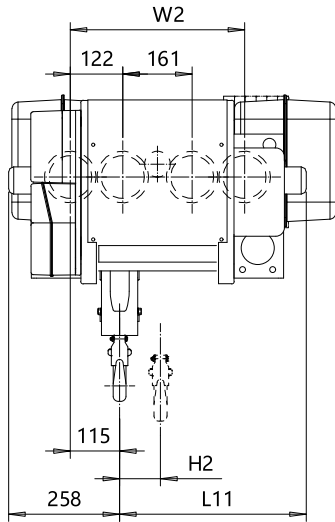

| HEADROOM TABLE - C DIMENSION | | |
|------------------------------|---------------------|--|
| Flange Width, B (mm) | Headroom, C (mm) | with HS22 Hook oper limit switch (mm) |
| 100 - 250 | 500 | 655 |
| 251 - 300 | 470 | 655 |
| 301 - 350 | 505 | 655 |
| 351 - 400 | 535 | 655 |
| 401 - 450 | 570 | 655 |
| 451 - 490 | 595 | 655 |
| 491 - 540 | 625 | 655 |
| 541 - 590 | 655 | 655 |
| 591 - 640 | 685 | 685 |
| 641 - 690 | 710 | 710 |

Headroom is related to the flange width

| HOL | Length | H2 | L11 | M1 | W2 | Approx Weight |
|-----|--------|------|------|------|------|---------------|
| (m) | code | (mm) | (mm) | (mm) | (mm) | (kg) |
| 12 | B | 95 | 346 | 356 | 405 | 378 |
| 18 | C | 144 | 446 | 456 | 505 | 398 |
| 24 | D | 193 | 546 | 556 | 605 | 418 |

| Load (kg) | Class |
|--------------|-------|
| 1600 | 3m/M6 |
| 2000 | 3m/M6 |
| 2500 | 2m/M5 |

| Motor | P3 | P4 | A3 | S3 | S5 |
|-------------|-----|-----|-----|-----|-----|
| MOT (mm) | 476 | 574 | 446 | 526 | 602 |
| Weight (kg) | 35 | 53 | 32 | 28 | 53 |

Approx. weight calculated with P1 motor.

This document is the absolute property of R&M Materials Handling, Inc. This document must not be copied without the written permission of R&M Materials Handling, Inc. The contents thereof must not be disclosed to a third party nor be used for any unauthorized purpose. Contravention will be prosecuted.

| | | | |
|---------------------------------------|---|-------------|---------------|
| ETPAL Design 2002-08-27 Date | ETPAL Chd Appd | Ref Drawing | QB-L-02 |
| SLEDDOCV Owner Dept | TROLLEY; LOW HEADROOM 2 ROPE FALLS | | 1-75 FoMar |
| R&M MATERIALS HANDLING INC. | R&M MATERIALS HANDLING INC HOIST & CRANE PRODUCTS SPRINGFIELD, OHIO | D002087-A | Issue 8 |