

**NORMAL HEADROOM, CURVED TRACK; 2 PART SINGLE**  
**Hoist type:**  
**SX4021...N0**

SI

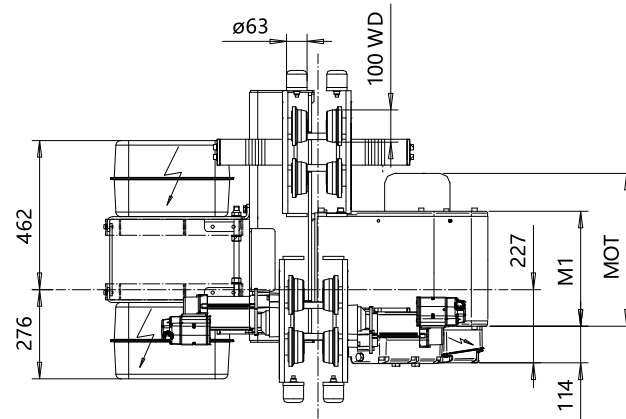

Track Radius	
Flange width B	R min
90 - 109	2500
110 - 119	2000
120 - 350	1500

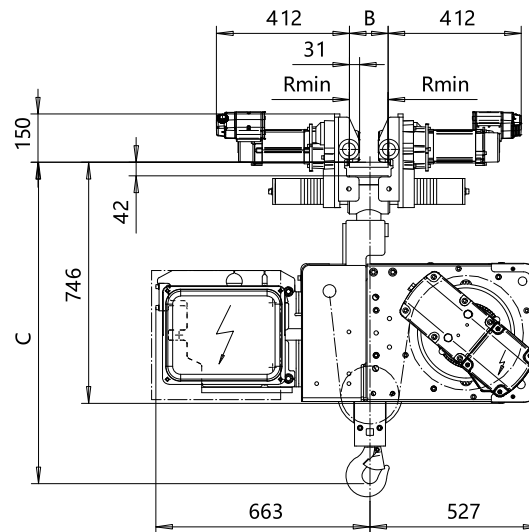
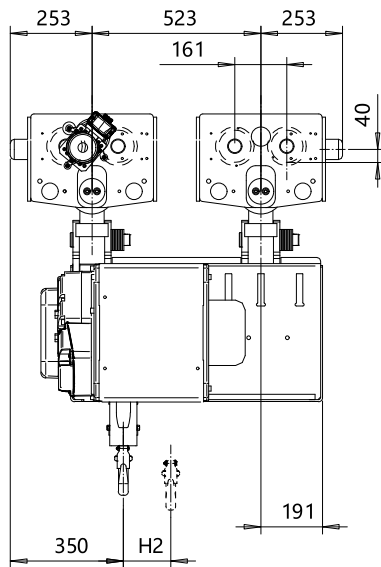

Headroom - C dimension	
Standard	1085 mm
with HS22 Hook operated limit switch	1095 mm

Motor	P3	P4	A3	S3	S5
MOT (mm)	476	574	446	526	602
Weight (kg)	35	53	32	28	53

Hoist Dimensions				
HOL	Length	H2	M1	Approx Weight
(m)	code	(mm)	(mm)	(kg)
12	B	98	356	523
18	C	147	456	543
24	D	198	556	583
30	E	258	676	593

Load	Class
(kg)	Fem/ISO
1600	3m/M6
2000	3m/M6
2500	2m/M5

This document is the absolute property of R&M Materials Handling, Inc. This document must not be copied without the written permission of R&M Materials Handling, Inc. The contents thereof must not be disclosed to a third party nor be used for any unauthorized purpose. Contravention will be prosecuted.

ETVPH Design	ETVPH Chd	Appd	Ref Drawing	QB-N-02
2004-12-23 Date	TROLLEY; NORMAL HEADROOM			 3-1-10 For Mar
SLEDDOCV Owner Dept	CURVED TRACK; 2 ROPE FALLS			
 R&M MATERIALS HANDLING INC.	R&M MATERIALS HANDLING, INC. HOIST & CRANE PRODUCTS SPRINGFIELD, OHIO		D003840-A	Issu 6